



GRID-CONNECTED PV SYSTEMS

SYSTEM INSTALLATION GUIDELINES



Acknowledgement

The development of this guideline was funded through the Sustainable Energy Industry Development Project (SEIDP). The World Bank through Scaling Up Renewable Energy for Low-Income Countries (SREP) and the Small Island Developing States (SIDSDOCK) provided funding to the PPA as the Project Implementation Agency for the SEIDP. The guidelines have been developed by Global Sustainable Energy Solutions with the support of Dr Herbert Wade and reviewed by PPA and SEIAPI Technical Committees.



These guidelines have been developed for The Pacific Power Association(PPA) and the Sustainable Energy Industry Association of the Pacific Islands (SEIAPI). They represent latest industry BEST PRACTICE for the design of Grid Connected PV Systems
© Copyright 2019

While all care has been taken to ensure this guideline is free from omission and error, no responsibility can be taken for the use of this information in the design of any grid connected PV System.

Table of Contents

1.	Introduction.....	1
2.	Standards for Installation.....	3
3.	Voltage Limits and Work Restrictions.....	4
4.	PV Modules.....	5
5.	PV Array Installation.....	6
	5.1 General.....	6
	5.2 Maximum PV Array Voltage.....	6
	5.3 Orientation and Tilt.....	8
	5.4 Roof Mounting (Not Building Integrated).....	11
	5.5 Free Standing PV Arrays.....	12
	5.6 Building Integrated (BIPV) Installations.....	12
	5.7 Attaching Modules to Array Mounting Structure.....	12
6.	PV Array Wiring.....	14
	6.1 Selection of dc cable.....	14
	6.2 Installation of the PV Array Wiring.....	14
	6.3 Calculating Voltage Drop (Metric).....	15
	6.4 Calculating Voltage Drop (Imperial).....	16
	6.5 Wiring Loops.....	17
	6.6 Selection of Current Carrying Capacity of PV String Cables.....	19
	6.7 Selection of Current Carrying Capacity of PV Array Cables.....	19
	6.8 Selection of Cables when Array Comprises Sub-Array PV Systems.....	20
	6.8.1 PV Array Cables.....	20
	6.8.2 PV Sub-Array Cables.....	20
	6.8.3 PV String Cables.....	21
7.	Disconnection Requirements within an Array.....	22
8.	Safe Installation Practice.....	22
9.	Earthing (Grounding) of Array Frames for a PV Array with Maximum Voltage Greater than ELV (including ac modules and micro-inverter systems).....	23
10.	Installation of PV Array Cable between Array and Inverter.....	24
11.	dc Cable Protection.....	25
	11.1 Fuses.....	25
	11.2 String Protection.....	25
	11.3 Sub-Array Protection.....	26
	11.4 Requirements of Sub-array Overcurrent Protection.....	26

11.5 Sizing the Sub-array Overcurrent Protection.....	26
11.6 Array Protection.....	26
11.7 Arc Fault Protection (countries following NEC requirements).....	26
11.8 Rapid Shutdown of PV Systems on Buildings (countries following NEC requirements).....	27
12. Installation of Combiner Boxes.....	27
13. Segregation of dc and ac circuits.....	27
14. Plugs and Sockets.....	27
15. Inverter Installation.....	28
15.1 Inverter Earth (Ground) Fault Indication (for Countries following NEC refer to section 15.3).....	28
15.2 Additional Requirements for Module Inverters.....	28
15.3 Ground Fault Protection (countries following NEC requirements).....	29
16. Switch Disconnectors.....	29
16.1 PV Array dc Switch Disconnecter near Inverter.....	29
16.2 dc Switch-Disconnecter Requirements.....	30
16.3 ac Switch-Disconnecter near Inverter.....	30
16.4 Solar Supply Main Switch in Switchboard.....	32
16.5 ac Isolator for Micro Inverter Installation.....	32
17. Installation of ac Cable between Inverter and the Grid.....	32
17.1 Voltage Drop in ac Cables.....	32
18. Shutdown Procedure.....	33
19. Metering.....	34
20. Signage.....	34
21. Commissioning.....	35
21.1 Short Circuit Current Measurement.....	35
21.2 Insulation Resistance Measurement.....	36
22. Documentation.....	36
Appendix 1: Temperature Conversion Tables.....	37
Appendix 2: Installation and Commissioning Sample.....	38

List of Figures

Figure 1: Grid connected PV systems.....	1
Figure 2: Wiring schematic (AS/NZ).....	2
Figure 3: Wiring schematic (NEC).....	2
Figure 4: Example of tilt angles.....	9
Figure 5: Example of array clamps.....	12
Figure 6: Module clamps.....	13
Figure 7: 50mm (2inch) mid-clamps.....	13
Figure 8: Double insulated solar dc cable.....	14
Figure 9: Example of wiring to avoid conductive loops.....	17
Figure 10: Example of wiring to avoid conductive loops.....	18
Figure 11: Example of wiring to avoid conductive loops.....	18
Figure 12: Example of wiring that will cause conductive loops and not to be done	18
Figure 13: Current carry capacity of cables with string fusing.....	19
Figure 14: Current carry capacity of cables with no string fusing.....	20
Figure 15: Array with sub-array fusing.....	21
Figure 16: Disconnected interconnect cable.....	22
Figure 17: A collar flashing on a metal roof.....	24
Figure 18: Paralleling of strings on the inverter side of the device.....	30
Figure 19: An ac switch-disconnector is not required – the distance between the switchboard and the inverter is less than 3m (10 feet) and the inverter is visible from the switchboard.....	31
Figure 20: An ac switch-disconnector is required – the distance is greater than 3m or the switchboard is not visible from the inverter.....	31
Figure 21: As ac switch-disconnector required – the switchboard is away from the line of sight.....	31
Figure 22: Measuring short circuit current.....	35

List of Tables

Table 1: Decisive Voltage Classification (DVC).....	4
Table 2: Voltage correction factors for monocrystalline and polycrystalline silicon PV modules.....	8
Table 3: Sites for orientation and tilt tables in Appendix 3 of Design Guideline.....	10
Table 4: Cable resistance for uncoated copper cable at 75°C (167°F).....	16
Table 5: Minimum insulation resistance for various system voltages.....	36

List of Abbreviations

A summary of the main acronyms and terms used in this document is listed below:

AC	Alternating Current
AS	Australian Standards
AWG	American Wire Gauge
CCC	Current Carrying Capacity
CSA	Cross Section Area
DC	Direct Current
DLVC	Decisive Voltage Classification
ELV	Extra Low Voltage
EN	European Standards (European Norms)
GFPD	Ground Fault Protective Device
IEC	International Electrotechnical Commission
KW_p	Kilowatts Peak Power
KWh	Kilowatt Hour
LV	Low Voltage
MPPT	Maximum Power Point Tracker
NZS	New Zealand Standards
NEC	National Electricity Code
PV	Photovoltaic
STC	Standard Test Conditions
UL	Underwriters Laboratories

1. Introduction

This document provides the minimum requirements when installing a grid connected PV system.

The array requirements are generally based on the requirements of: IEC62548 (PV Arrays-Design Requirements). These are similar to the requirements of AS/NZS5033: Installation and Safety Requirements of PV Arrays. The National Electrical Code (NEC) specifies maximum currents for strings, sub-arrays and arrays of 1.25 times the short circuit currents of the strings, sub-arrays and arrays. For protection and isolation devices the NEC has a required safety margin of 1.25(125%), thereby having an effective overall oversizing of 156% (1.56 times) the relevant short circuit currents. The NEC requirements are provided as notes where appropriate.

Figure 1 shows a typical interconnection of a grid connected PV system while Figures 2 and 3 are typical wiring schematic.

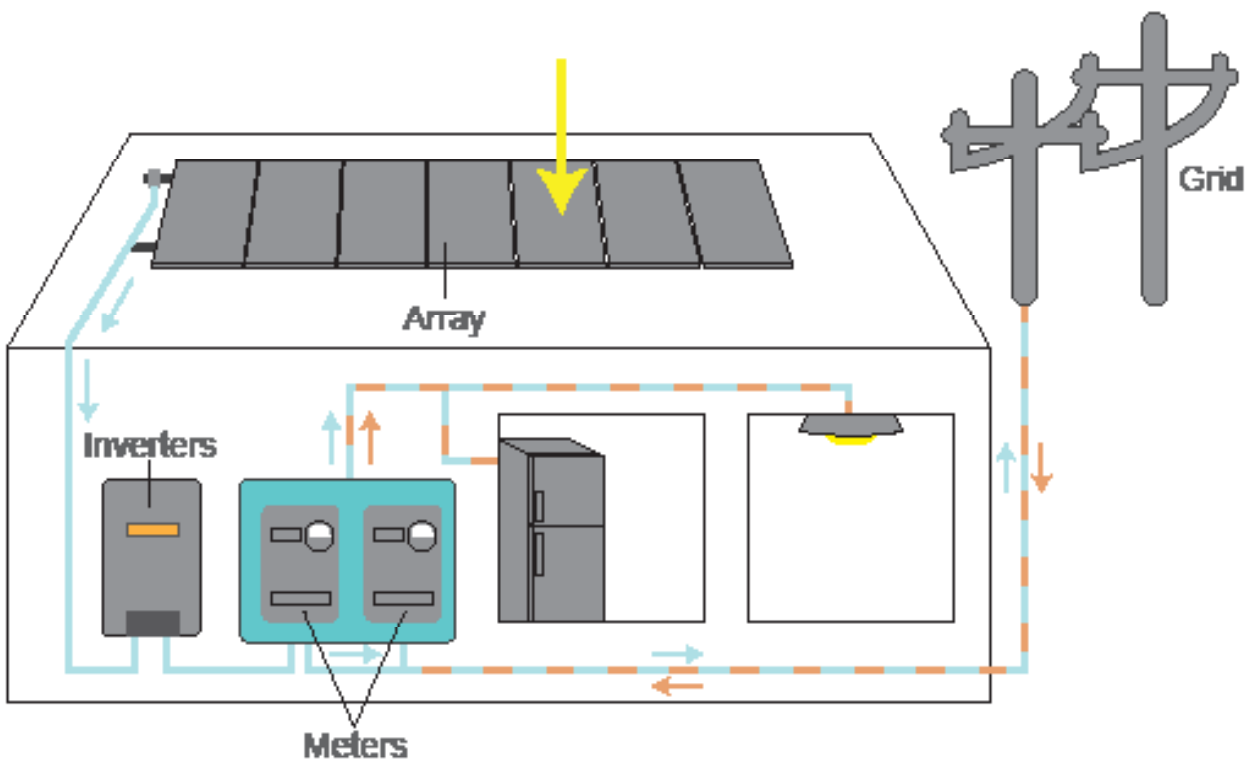

Figure 1: Grid connected PV systems

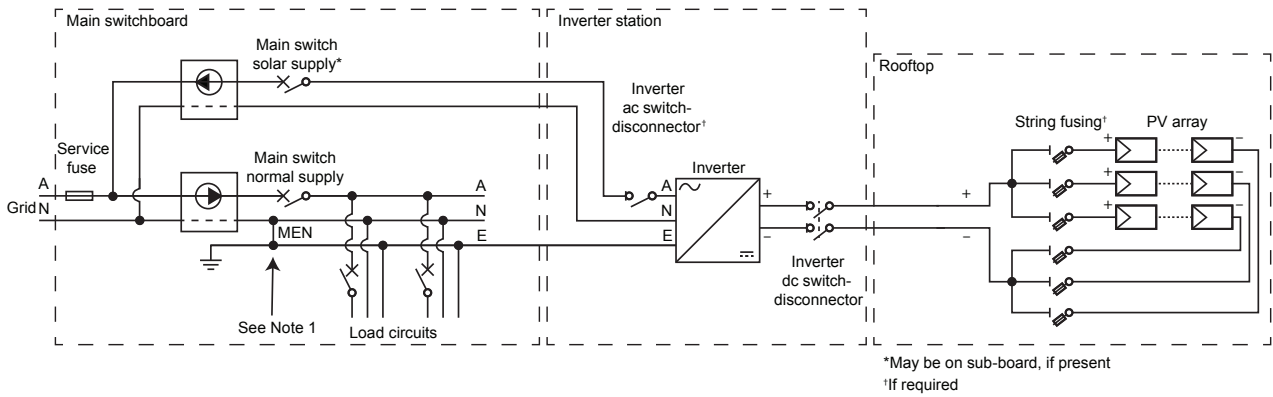

Figure 2: Wiring schematic (AS/NZS)

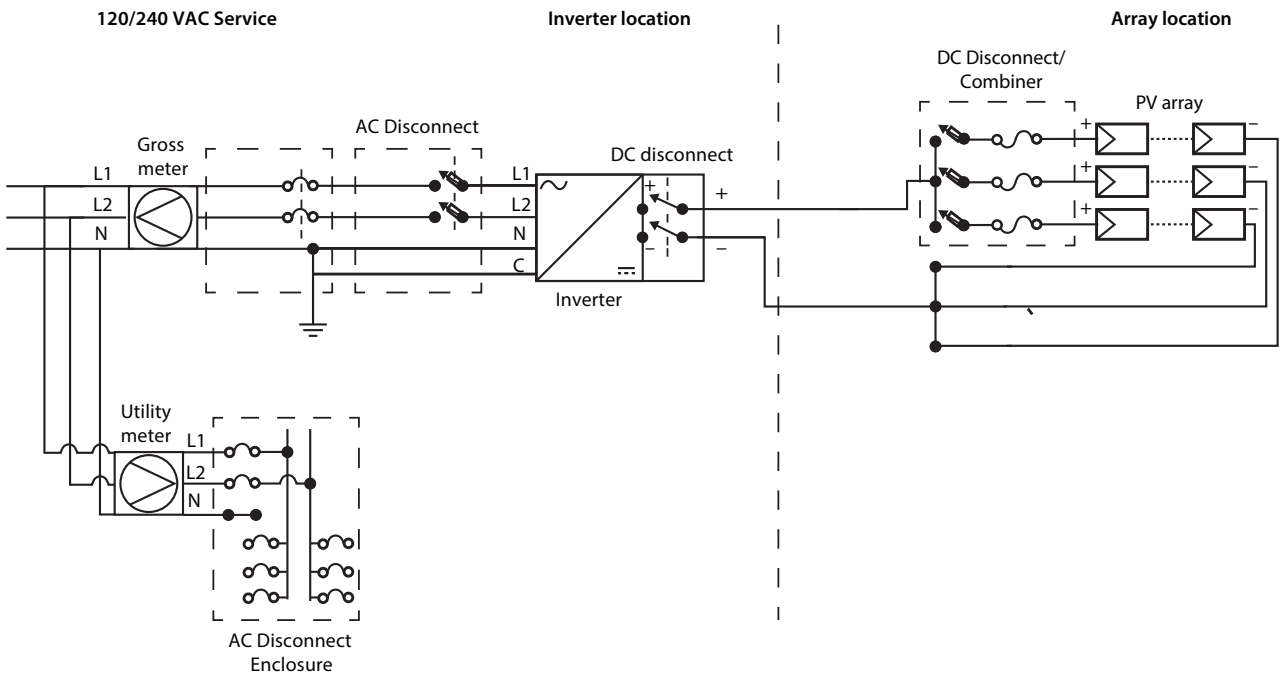

Figure 3: Wiring schematic (NEC)

Notes:

1. IEC standards use a.c. and d.c. for alternating and direct current respectively while the NEC uses ac and dc. This guideline uses ac and dc.
2. In this document there are calculations based on temperatures in degrees centigrade (°C). The formulas used are based on figures provided from solar module manufactures where the temperature coefficients are generally expressed in °C in degrees while there are some from the USA that have used degrees kelvin (K). A one-degree change in C is equal to a one-degree change in K. So if the module manufacturer provides the temperature coefficient in K, just change the K to °C.

If your local temperatures are given in Fahrenheit degrees, to use the formulas shown in this guideline, you must convert °F to °C. For your convenience in making that conversion, Appendix 1 is a table to convert from °F to °C from 32°F to 127 °F (0°C to 53 °C). Use the appropriate Fahrenheit number in a °F column and use the number in the adjacent °C column in the formulas given in this guideline.

2. Standards for Installation

System installation should follow any standards that are typically applied in the country or region where the solar installation will occur. The following are the relevant standards in Australia, New Zealand and USA. Some Pacific island countries and territories do follow those standards. These standards are often updated and amended so the latest version should always be applied.

Some Pacific Islands Utilities are also introducing their own guidelines and requirements that must be followed when installing grid connected PV systems in those countries.

In Australia and New Zealand, the relevant standards include:

- AS/NZS 1768 Lightning Protection.
- AS/NZS 3000 Wiring Rules.
- AS/NZS 3008 Electrical Installations-Selection of Cables.
- AS/NZS 3598 Energy audits.
- AS/NZS 4509 Stand-alone power systems (note some aspects of these standards are relevant to grid connect systems).
- AS/NZS 4777.1 Grid connection of energy systems via inverter:
Installation requirements
- AS/NZS 4777.2 Grid connection of energy systems via inverter:
Inverter requirements
- AS/NZS 5033 Installation and Safety Requirements of PV Arrays.
- IEC 61215 Terrestrial photovoltaic (PV) modules-
Design qualification and type approval
 - IEC 61215-1 Part 1: Test requirements
 - IEC 61215-1-1 Part 1-1: Special requirements for testing of crystalline silicon photovoltaic (PV) modules
 - IEC 61215-1-2 Part 1-2: Special requirements for testing of thin-film Cadmium Telluride (CdTe) based photovoltaic (PV) modules
 - IEC 61215-1-3 Part 1-3: Special requirements for testing of thin-film amorphous silicon based photovoltaic (PV) modules
 - IEC 61215-1-4 Part 1-4: Special requirements for testing of thin-film Cu(In,Ga)(S,Se)₂ based photovoltaic (PV) modules
 - IEC 61215-2 Part 2: Test Procedures
- IEC 61730 Photovoltaic (PV) module safety qualification.
 - IEC 61730-1 Part 1: Requirements for construction.
 - IEC 61730-2 Part 2: Requirements for testing.
- IEC 62109 Safety of power converter for use in photovoltaic power systems.
 - IEC 62109-1 Part 1: General requirements.
 - IEC 62109-2 Part 2: Particular requirements for inverters.

In USA the relevant codes and standards include:

- Electrical Codes-National Electrical Code (NEC) and NFPA 70:
 - Article 690: Solar Photovoltaic Systems.
 - Article 705: Interconnected Electric Power Production.
- Building Codes- ICC, ASCE 7
- UL Standard 1703 Flat Plate Photovoltaic Modules and Panels.
- IEEE 1547 Standards for Interconnecting Distributed Resources with Electric Power Systems.
- UL Standard 1741 Standard for Inverter, converters, Controllers and Interconnection System Equipment for use with Distributed Energy Resources.
- UL 62109 Standard for Safety of Power Converters for Use in Photovoltaic Power Systems.
- UL 2703 Standard for Mounting Systems, Mounting Devices, Clamping/Retention Devices, and Ground Lugs for Use with Flat-Plate Photovoltaic Modules and Panels.
- UL(IEC) 61215 Crystalline silicon terrestrial photovoltaic (PV) modules— Design qualification and type approval.
- UL(IEC) 61646 Thin-film terrestrial photovoltaic (PV) modules— Design qualification and type approval.

3. Voltage Limits and Work Restrictions

System voltage classification in this guideline follow the Decisive Voltage Classification (DVC) as defined in the standard: IEC 62109 Safety of power converter for use in photovoltaic power systems as shown in Table 1. The Decisive Voltage Classification has not been adopted by the NEC at this stage.

Table 1: Decisive Voltage Classification (DVC)

Decisive voltage classification (DVC)	Limits of working voltage (V)		
	ac voltage (rms)	ac voltage (peak)	dc voltage (mean)
DVC-A	$V \leq 25$	$V \leq 35.4$	$V \leq 60$
DVC-B	$25 < V \leq 50$	$35.4 < V \leq 50$	$60 < V \leq 120$
DVC-C	$V > 50$	$V > 71$	$V > 120$

Some countries in the Pacific follow the voltage limits as defined in the Australian/New Zealand standard AS/NZS3000 where:

- Extra Low Voltage (ELV) is <120V dc or <50V ac
- Low Voltage (LV) is >120V dc and <1500V dc or >50V ac and <1000 ac

In following this some countries do have licensed or registered electricians impose the following requirements:

Extra Low Voltage Work:

- All extra low voltage wiring should be performed by a 'competent' person, which is defined in various standards: "a person who has acquired through training, qualifications, experience or a combination of these, knowledge and skill enabling that person to correctly perform the task required."

Low Voltage Work

- All low voltage work: >120V dc or >50V ac should be performed by a trained electrician or similar (e.g. licensed or registered).
- A trained electrician should be responsible for the safety of the system wiring prior to connection of the system to the grid.
- If the system contains ELV wiring installed by a person not a trained electrician, then a minimum level of inspection by the electrician prior to closing the PV array isolators would include:
 - an open circuit voltage test on each PV string and on the total array.
 - a visual inspection of an open PV junction box (randomly selected) and the master array junction box.

These inspections/checks shall confirm:

- the array voltages are as designed and specified.
- the appropriate cable cross section area and insulation specifications, junction fittings and enclosures have been used.

Both the non-electrician ELV installer, as well as the licensed electrician, are expected to carry out the checks on the ELV wiring.

In the NEC standard anything above 60V dc is considered dangerous. Except when module inverters are used, grid connect PV arrays have open circuit voltage typically above 120V dc and hence considered LV. LV is dangerous and can kill a person if they come into contact with live terminals.

4. PV Modules

All solar modules shall comply with either:

The following IEC standards:

- | | |
|--------------------|---|
| - IEC 61215 | Terrestrial photovoltaic (PV) modules - Design qualification and type approval |
| • IEC 61215-1 | Part 1: Test Requirements |
| • One of IEC 61215 | Part 1.1, Part 1.2 Part 1.3, part 1.4 which all relate to specific types of modules e.g. crystalline, thin film amorphous etc (See Section 2) |
| • IEC 61215-2 | Part 2: Test Procedures |
| - IEC 61730 | Photovoltaic (PV) module safety qualification |
| - IEC 61730-1 | Part 1: Requirements for construction |
| - IEC 61730-2 | Part 2: Requirements for testing |

Or

The UL standard

- | | |
|---------------------|--|
| - UL Standard 1703: | Flat Plate Photovoltaic Modules and Panels |
|---------------------|--|

For modules with IEC certification they must be certified as Application Class A per IEC 61730.

5. PV Array Installation

5.1 General

- PV arrays for installation on domestic dwellings shall not have PV array maximum voltages greater than 600 V.
- Modules that are electrically in the same string and connected to the same maximum power point tracker (MPPT) shall be all in the same orientation.
- A minimum tilt of 10° is recommended to take advantage of self-cleaning during rain events. Horizontally mounted arrays will require additional maintenance [cleaning] and this should be included in the recommended maintenance schedule.

5.2 Maximum PV Array Voltage

The PV Array Maximum voltage can be calculated using the minimum expected temperature at a site and the temperature coefficient of a module.

The maximum open circuit voltage (V_{oc}) of a module is determined by calculating the increase in V_{oc} due to the effective cell temperature.

The increase in V_{oc} is calculated by multiplying the voltage temperature coefficient ($V/^\circ C$) by the difference between the effective cell temperature and the standard test condition (STC) temperature of 25°C (77°F).

If the temperature is 15°C (59°F), then the increase in V_{mp} is $(15^\circ C - 25^\circ C) = -10$ times the voltage temperature coefficient ($V/^\circ C$).

Note: It is an increase because the co-efficient is a negative number and the difference in temperatures is also a negative number, so the two multiplied becomes a positive number.

The effective V_{oc} of the module at the minimum module temperature = V_{oc} plus any change in V_{oc} due to the temperature of the module not being 25°C (77°F).

Worked Example 1

(Refer to Design Guideline for Grid Connected PV Systems)

Assume the minimum effective cell temperature is 15°C (59°F),

The module data sheet provides the following information:

- $V_{oc} = 37.7V$
- V_{oc} temperature coefficient = 0.32%/°C

Therefore, in V/°C the V_{oc} temperature coefficient = $-0.32/100$ per degree C $\times 37.7V = -0.121V/°C$

Based on the minimum temperature of 15°C then the:

$$\begin{aligned}\text{Increase in } V_{oc} \text{ due to temperature} &= -10°C \text{ times the voltage temperature coefficient (V/°C)} \\ &= -10°C \times -0.121V/°C \\ &= 1.21V\end{aligned}$$

So the effective maximum V_{oc} of the module due to temperature = $37.7V + 1.21 = 38.91V$ dc for each module in the string.

(For countries that use °F, use the supplied conversion tables to convert the minimum temperature in °F to °C then proceed as in the above example)

The maximum V_{oc} of the string is then calculated by multiplying the maximum V_{oc} of one module by the number of the modules in the string. Thus, in the example above, if there are 11 panels in a string, the maximum V_{oc} of the string will be $11 \times 38.91 = 428.01 V_{dc}$.

If the temperature coefficients are not available and the array uses monocrystalline or polycrystalline modules, the PV array maximum voltage can be estimated by using the below table containing the temperature ranges and multiplication factors.

Note: This table does not apply if the modules are thin-film types, the voltage/temperature coefficient for the specific thin-film modules in use should be obtained from the module manufacturer.

Table 2: Voltage correction factors for monocrystalline and polycrystalline silicon PV modules

Lowest expected operating temperature (degrees Celsius)	Correction factor	Lowest expected operating temperature (degrees Fahrenheit)
24 to 20	1.02	76 to 68
19 to 15	1.04	67 to 59
14 to 10	1.06	58 to 50
9 to 5	1.08	49 to 41
4 to 0	1.10	40 to 32
-1 to -5	1.12	31 to 23
-6 to -10	1.14	22 to 14
-11 to -15	1.16	13 to 5
-16 to -20	1.18	4 to -4
-21 to -25	1.20	-5 to -13
-26 to -30	1.21	-14 to -22
-31 to -35	1.23	-23 to -31
-36 to -40	1.25	-32 to -40

5.3 Orientation and Tilt

In grid connected PV systems the solar array is generally mounted:

- "Flat" on the roof, that is parallel to the slope of the roof but raised off the roof
- OR
- Integrated into the building
- OR
- On an array frame that is tilted to fix the array at a preferred angle (usually for flat roofs or ground mounted).

For best year-round performance a fixed PV array typically should be mounted facing true north ($\pm 10^\circ$) in the South Pacific and true south ($\pm 10^\circ$) in the North Pacific at an inclination equal to the latitude angle or at an angle that will produce the best annual average performance taking into consideration: seasonal cloud patterns, local shading and environmental factors. In the tropics this could vary due to the sun being in both north and south at different times of the year.

Between latitudes 10° South and 10° North the array should be tilted at a minimum of 10 degrees. If the array is "flat" on the roof (that is parallel to the slope of the roof) or integrated into the building, the array will often not be at the preferred (optimum) tilt angle and in many situations will not be facing due north or due south however the effect on energy output due to installations not being at the optimum tilt and orientation is usually small for installations in the tropics.

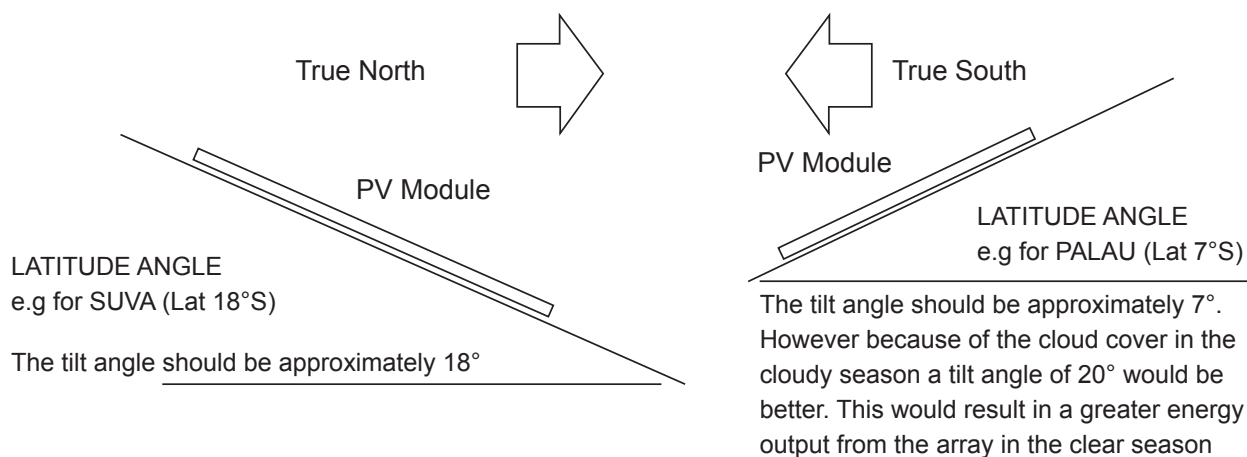

Figure 4: Examples of tilt angles

Included with the design guide (Appendix 2) is a set of tables for the following locations:

- Alofi, Niue (Latitude 19°04'S, Longitude 169°55'W)
- Apia, Samoa (Latitude 13°50'S, Longitude 171°46'W)
- Hagåtña, Guam (Latitude 13°28'N, Longitude 144°45'E)
- Honiara, Solomon Islands (Latitude 09°27'S, Longitude 159°57'E)
- Koror, Palau (Latitude 7°20'N, Longitude 134°28'E)
- Lae, Papua New Guinea (Latitude 6°44'S, Longitude 147°00'E)
- Majuro, Marshall Islands (Latitude 7°12'N, Longitude 171°06'E)
- Nauru (Latitude 0°32'S, Longitude 166°56'E)
- Nouméa, New Caledonia (Latitude 22°16'S, Longitude 166°27'E)
- Nuku'alofa, Tonga (Latitude 21°08'S, Longitude 175°12'W)
- Pago Pago, American Samoa (Latitude 14°16'S, Longitude: 170°42'W)
- Palikir, Pohnpei FSM (Latitude 6°54'N, Longitude 158°13'E)
- Port Moresby, Papua New Guinea (Latitude 9°29'S, Longitude 147°9'E)
- Port Vila, Vanuatu (Latitude 17°44'S, Longitude 168°19'E)
- Rarotonga, Cook Islands (Latitude 21°12'S, Longitude 159°47'W)
- Suva, Fiji (Latitude 18°08'S, Longitude 178°25'E)
- Tarawa, Kiribati (Latitude 1°28'N, Longitude 173°2'E)
- Vaiaku, Tuvalu (Latitude 8°31'S, Longitude 179°13'E)

These tables show the average daily total irradiation for each month of the year for: surface at horizontal, a surface tilted at latitude and for a surface tilted at latitude plus 15 degrees.

When the roof is not oriented true north (southern hemisphere) or true south (northern hemisphere) and/or not at the optimum inclination, the output from the array will generally be less than the maximum possible though local conditions may cause some variations in that rule.

Appendix 3 of the design guideline provides tables that the variation in irradiation due to different tilts and azimuths from the optimums as shown for the locations listed in Table 3. The tables show the average daily total irradiation represented as a percentage of the maximum value i.e. PV orientation is true North (azimuth = 0°) in the Southern Hemisphere or true South in the Northern Hemisphere (azimuth = 180°) with an array tilt angle equal to the latitude angle or 10° whichever is greater¹. If the location for the system you are designing is not shown it is recommended that you use the site with the latitude closest to your location.

Table 3: Sites for orientation and tilt tables in Appendix 3 of Design Guideline

N°	Site	Latitude	Longitude
1	Nauru	0°32' South	166°56' East
2	Vaiaku, Tuvalu	8°31' South	179°13' East
3	Apia, Samoa	13°50' South	171°46' West
4	Suva, Fiji	18°08' South	178°25' East
5	Tongatapu, Tonga	21°08' South	175°12' West
6	Palikir, Pohnpei FSM	6°54' North	158°13' East
7	Hagåtña, Guam	13°28' North	144°45' East

The tables in Appendix 3 of the Design Guide provide values for an array mounted in 36 orientations (azimuths) and 10 inclination (tilt) angles in increments of 10°.

Using these tables will provide the system installer with information on the expected output of a system (with respect to the maximum possible output) when it is located on a surface that is not facing true north (or south) or at an inclination not equal to the latitude angle. The designer can then use the peak sun hour data for the site to determine the expected peak sun hours of sun falling on the array at the actual orientation and tilt angle for the system to be installed. Note that in the case of arrays that are mounted on several roofs at different orientations and tilts, each roof must have the solar input calculated separately as the kWh per individual roof then all the kWh that result can be added together to get the total from all the modules in the installation.

¹ It is not advisable to mount panels at a tilt angle less than 10° since panels need to be self-cleaned by the rapid run-off of rain.

5.4 Roof Mounting (Not Building Integrated)

- If the modules use crystalline cells, then it is preferable to allow sufficient space below the array (> 50mm or 2 inches) for cooling by natural ventilation. Insufficient cooling will result in high module operating temperatures and lower outputs from the panels.
- It is important to allow sufficient clearance to facilitate self-cleaning of the roof to prevent the build-up of leaves and other debris.
- If fauna (e.g. rats) are a problem in the vicinity of the installation, then consideration should be given as to how to prevent them gaining access under the array (see cable protection).
- The array structures shall be designed to withstand the aggressively salty atmosphere.
- All array supports, brackets, screws and other metal parts shall be of suitable low-corrosion materials suitable for the lifetime and duty of the system, that do not increase their rates of corrosion when mounted together in an array, and when mounted on the surface of the underlying structure. This may include techniques to minimise corrosion rates appropriate to the local environment, including but not restricted to methods such as: non-reactive separators between metal surfaces and under screw and bolt heads; and selection of materials with an appropriate type and thickness of anti-corrosive coating.
- Where timber is used it must be suitable for long-term external use and fixed so that trapped moisture cannot cause corrosion of the roof and/or rotting of the timber. The expected replacement time should be stated in the system documentation.
- Any roof penetrations must be suitably sealed and remain waterproof for the expected life of the system. If this is not possible then this must be detailed in the Maintenance Timetable
- If the roof is using tiles, tiles shall sit flat after the installation of tile mounting brackets to ensure the tiles maintain their original ingress protection. There may be a requirement to grind some of the underside of the tile to enable it to sit correctly.
- For metal roofs the array frame structure should be attached to the roof using brackets that are screwed through the ridges of the roof into a purlin or rafter below.
- All fixings must ensure structural security when subject to the highest wind speeds likely in the region and local terrain
- This may require specific tests of the fixing/substrate combination on that roof. For those countries which have experienced Category 3 to category 5 cyclones typhoons in the past shall have the frames and module attachments designed to meet the wind speeds expected in a Category 5 cyclone/typhoon.
- The installer shall ensure that the array frame that they install has applicable engineering certificates verifying that the frame meets wind loadings appropriate for that particular location.
- The installer must follow the array frame supplier's/manufacture's recommendations when mounting the array to the roof support structure to ensure that the array structure still meets wind loading certification. The installer shall also consider the following:
 - Area of roof applicable for modules to be installed
 - Type, length and gauge of screws to be used
 - Number of screws required per attachment
 - Size of batten/purlin required for attachment
- If necessary, refer to the roof manufacturer's guidelines to ensure that the materials introduced by the installation of PV array frames are compatible with the roofing material.

5.5 Free Standing PV Arrays

- The array mounting frames must be wind rated in accordance with relevant wind loading standards. For those countries which have experienced Category 3 to Category 5 cyclones typhoons then the frames shall be designed to remain intact in the wind speeds expected in a Category 5 cyclone/typhoon
- The array structures shall be designed to withstand the aggressively salty atmosphere.
- Installation of footings, posts, screws and/or in-ground fasteners shall follow manufacturer's instructions and installation manuals.

5.6 Building Integrated (BIPV) Installations

- The installation of modules that are being used as building materials (e.g. tiles, building walls windows, and sun-screens that have integrated solar generation elements) should only be installed by a person qualified to install that particular type of building element.

5.7 Attaching Modules to Array Mounting Structure

- Solar modules should be attached to the array structure either using the mounting holes provided by the manufacturer or via clamps that are suitable for the maximum wind at the site.
- The mounting of the PV modules should allow for the expansion and contraction of the PV modules under expected operating conditions.
- Where modules are installed in such way that a junction box is to the side or at the bottom, care must be taken to ensure this is permitted by the manufacturer.
- When using clamps, solar panel manufacturer's installation instructions shall be followed.

The installer shall consider the following:

- amount of overhang allowed from clamp to end of module
- size of clamp required

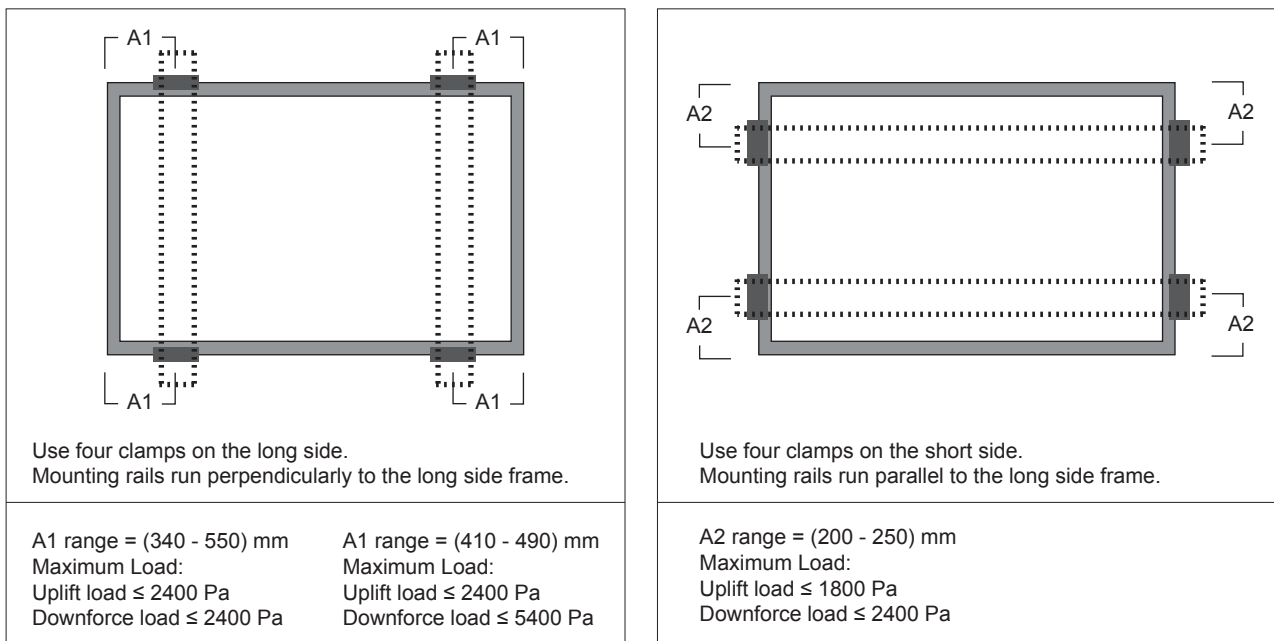

Figure 5: Example of array clamps (Source: Canadian Solar)

- ④ Ensure the clamps overlap the module frame by at least 5 mm (0.2 in)
- ⑤ Ensure the clamps overlap length is at least 40 mm (1.57 in)
- ⑥ Ensure the clamp's thickness is at least 3 mm (0.12 in)

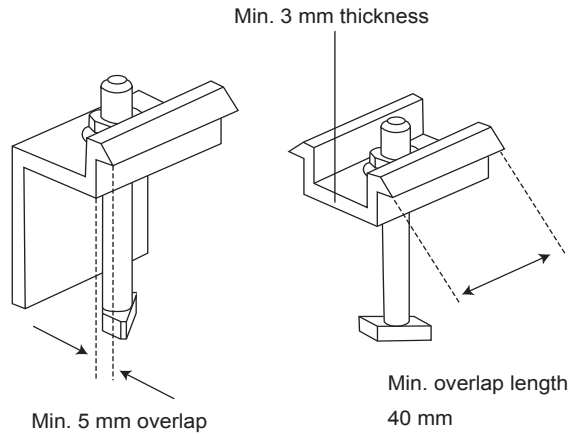

Figure 6: Module clamps (Source: Canadian Solar)

Note: Attaching a solar module in such a manner (e.g. drilling, pop riveting) that causes a hole in the anodised aluminium frame of the solar module typically voids the manufacturer's product warranty with respect to defects in material and workmanship. If the installer intends to undertake an installation in this manner, they shall obtain written verification from the manufacturer that it does not affect the warranty. This shall be included in the system documentation supplied to the customer.

What clamps in countries that experience Cyclones?

Experience in the last few years has shown that in countries that experience category 3 plus cyclones should have single module clamps on each module instead of dual module clamps. There have been a number of failures of dual module clamps due to cyclones which have resulted in a "zipper" effect where by one clamped module comes loose then the rest of the panels in that string are also loose.

Therefore, it is important that the array frame selected has been designed to be suitable for installation to withstand Category 5 cyclones. Array frames that are designed for winds experienced in Category 5 cyclones typically have mid-clamps longer than 50 mm (2 inches) in length and there can be as many as 3 railings per module. In a large system, consideration shall be given to using an end clamp for every fourth module so if one does become loose then only a few other modules would be affected, not necessarily the whole array.



Figure 7: 50mm (2 inch) mid-clamps

6. PV Array Wiring

6.1 Selection of dc cable



Figure 8: Double insulated solar dc cable

Cables used within the PV array wiring shall:

- Be suitable for dc applications,
- Have a voltage rating equal to or greater than the PV array maximum voltage determined in table 2.
- Have a temperature rating according to the application.
- If exposed to the environment, cables should be UV-resistant, be protected from UV light by appropriate protection, or installed in UV-opaque conduit that is itself UV-resistant,
- Be water resistant.
- If exposed to salt environments, have tinned copper, multi-stranded conductors to reduce degradation of the cable over time due to corrosion.
- In all systems operating at voltages above DVC-A, cables shall be selected so as to minimise the risk of earth faults and short-circuits. This is commonly achieved using reinforced or double insulated cables, particularly for cables that are exposed or laid in a metallic tray or conduit. This can also be achieved by reinforcing the wiring.
- It is recommended that string cables be flexible to allow for thermal/wind movement of arrays/module.
- Cables should comply with PV1-F requirements or UL 4703 or VDE-AR-E-2283-4.

Note: PV1-F cable requirements may be found in the document TUV 2 PfG 1169/08.2007.

6.2 Installation of the PV Array Wiring

- Plastic cable ties are not to be used as the primary means of wiring support.
- Cables shall not lay on roofs or the ground without an enclosure or conduit.
- Cables shall be protected from mechanical damage. Where the presence of fauna (e.g. rats) is expected to constitute a hazard, either the wiring system shall be selected accordingly, or special protective measures shall be adopted.
- All external wiring must be protected from UV either by using UV rated cables or installing the cables into enclosures/conduit that totally shields the cable insulation from UV exposure.
- All conduits exposed to direct sunlight shall be suitably UV rated.
- The installer shall ensure that all cable connectors used are waterproof and connected securely to avoid the possibility of a loose connection.
- Only cable connectors which are the same type/model from the same manufacturer are allowed to be married at a connection point.
- It is recommended that under maximum load conditions the voltage drop from the most remote module in the array to the input of the inverter should not exceed 3% of the V_{mp} voltage (at STC) for LV PV arrays.

Correctly sized cables in an installation will produce the following outcomes:

- No excessive voltage drops (which equates to an equivalent power loss) in the cables.
- The current in the cables will not exceed the safe current handling capability of the selected cables known as current carrying capacity (CCC)

6.3 Calculating Voltage Drop (Metric)

Voltage drop is calculated using Ohm's law:

$$V = I \times R$$

Combining this with the formula for calculating resistance, the voltage drop along a cable is given by:

$$V_d = \frac{2 \times L_{\text{CABLE}} \times I \times \rho}{A_{\text{CABLE}}}$$

$$\text{Voltage drop (in percentage)} = \frac{V_d}{V_{\text{MP}}} \times 100$$

Where:

- L_{CABLE} = route length of cable in metres (multiplying it by two adjusts for total circuit wire length since a complete circuit requires a wire out and another wire back along the route).
- I = current in amperes.
- ρ = resistivity of the wire in $\Omega/\text{m}/\text{mm}^2$
- A_{CABLE} = cross sectional area (CSA) of cable in mm^2 .
- V_{MP} = Maximum Power Point voltage in volts.

For PV arrays the current is the short circuit current (I_{sc}) of the string, sub-array or array. The Maximum line voltage in volts is the maximum power point voltage of the string, sub-array or array (V_{mp}).

Worked Example 2

A solar array has been installed and the distance between the output of the array and the inverter is 20 metres. The short circuit current of the array is 9.6A.

The cables have a cross sectional area of 4 mm^2

The cable is copper with a resistivity of 0.0183 ohms/metre/ mm^2

The array has maximum power point voltage of 540V.

$$V_d = \frac{2 \times L_{\text{CABLE}} \times I \times \rho}{A_{\text{CABLE}}}$$

$$= 2 \times 20 \times 9.6 \times 0.0183 / 4 \text{ V}$$

$$= 1.76 \text{ V}$$

$$\text{Voltage Drop in percentage} = \frac{V_d}{V_{\text{MP}}} \times 100$$

$$= 1.7 / 540 \times 100$$

$$= 0.33\%$$

6.4 Calculating Voltage Drop (Imperial)

To determine the voltage drop the following formula is used. The equation is derived from Ohm's Law i.e. $V=IR$:

$$V_d = \frac{I \times 2 \times d}{1000 \text{ ft /kft}} \times \left(\frac{\Omega}{\text{kft}} \right)$$

Where:

- V_d = voltage drop
- d = route length of dc cable in feet (2 x adjusts for total circuit wire length)
- I = dc current in amperes (commonly I_{mp})
- $\Omega//\text{kft}$ = ohms/thousand feet (resistance)

The resistance is dependent on the type of material. The resistance also depends on whether the cable is a single strand or multi-stranded.

$$\text{Voltage drop (in percentage)} = \frac{V_d}{V_{MP}} \times 100$$

Table 4 is an extract from the National Electric Code.

Table 4: Cable resistance for uncoated copper cable at 75°C (167°F)

Wire Size (AWG)	dc Resistance (Ohms per 1000 feet)	ac Resistance (Ohms to neutral per 1000 feet)
14	3.14	3.1
12	1.98	2.0
10	1.24	1.2
8	0.778	0.78
6	0.491	0.49
4	0.308	0.31
2	0.194	0.20
1	0.154	0.16
1/0	0.122	0.13
2/0	0.0967	0.10
4/0	0.0608	0.067

Worked Example 3

A solar array has been installed and the distance between the output of the array and the inverter is 66 feet. The short circuit current of the array is 9.6A.

The cable is AWG 10. The array has maximum power point voltage of 540V.

From Table 4, the dc Resistance in Ohms per 1000 feet =1.24

Therefore:

$$V_d = \frac{I \times 2 \times d}{1000 \text{ ft /kft}} \times \left(\frac{\Omega}{\text{kft}} \right)$$

$$= 9.6 \times 2 \times 66 \times 1.24/1000 \text{ V}$$
$$= 1.57\text{V}$$

$$\text{Voltage Drop (in percentage)} = \frac{V_d}{V_{MP}} \times 100$$

$$= 1.57/540 \times 100$$
$$= 0.29\%$$

6.5 Wiring Loops

Cables need to be laid in parallel close together to avoid wiring loops which could induce high voltages due to nearby lightning strikes. Figure 9, Figure 10 and Figure 11 give examples on how the conductive wiring loop can be avoided. Figure 12 shows what should not be done.

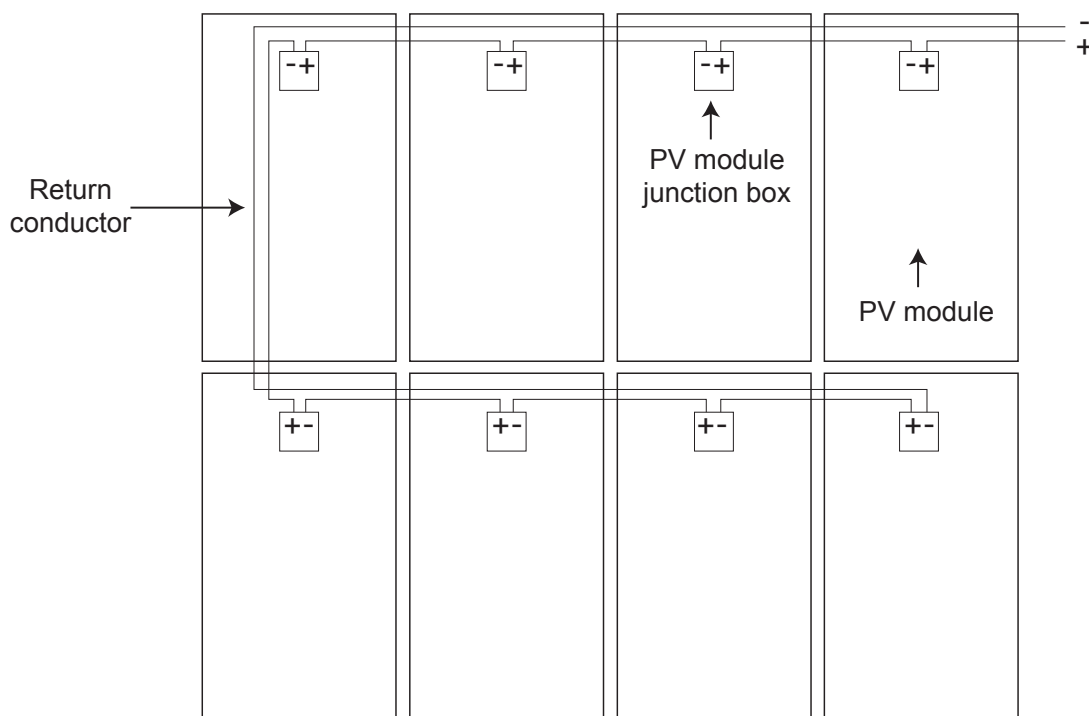

Figure 9: Example of wiring to avoid conductive loops

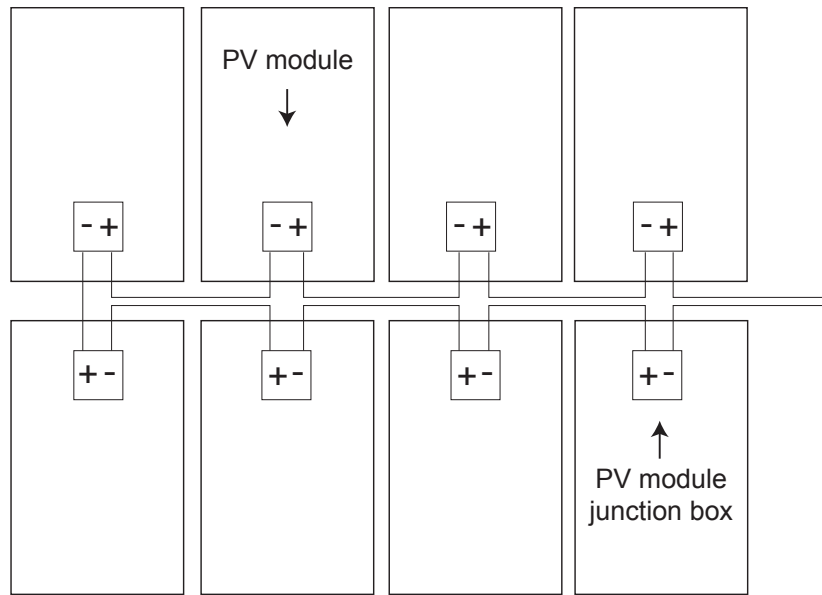

Figure 10: Example of wiring to avoid conductive loops

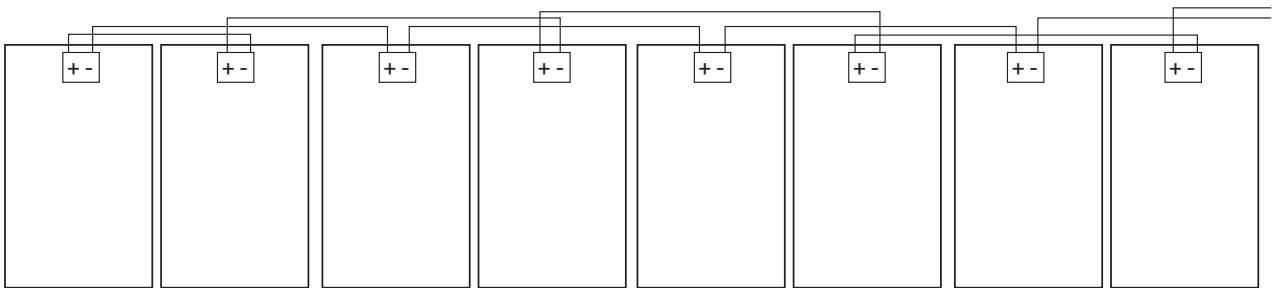

Figure 11: Example of wiring to avoid conductive loops

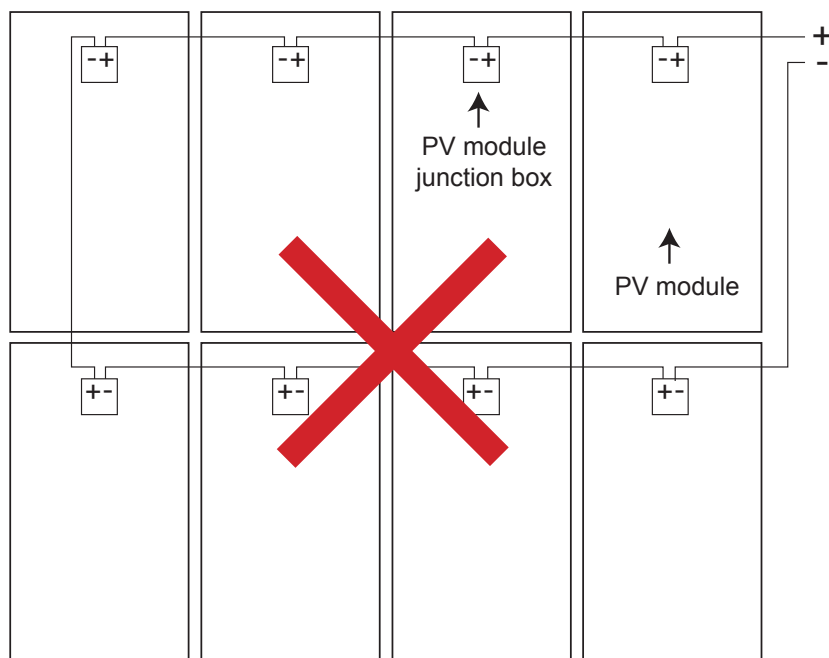

Figure 12: Example of wiring that will cause conductive loops and not to be done.

6.6 Selection of Current Carrying Capacity of PV String Cables

- If a fault current protection device is located in the string cable, the string cable must have a rating equal to or greater than the current rating of the fault current protection device. For example, if the fault current protection device is rated at 8A, the string will need to be rated with a current carrying capacity (CCC) of a minimum of 8A.
- If no fault current protection is provided, the current carrying capacity (CCC) of the string cable will be rated according to:

$$CCC \geq 1.25 \times I_{SC\ MOD} \times (\text{Number of Parallel Connected Strings} - 1) + I_n$$

Where:

$I_{SC\ MOD}$ = short circuit current of PV module.

I_n = current rating of the nearest downstream overcurrent protection device.

6.7 Selection of Current Carrying Capacity of PV Array Cables

- The current carrying capacity (CCC) of the PV array cable will be rated according to:

$$CCC \geq 1.25 \times I_{SC\ ARRAY}$$

Where:

$I_{SC\ ARRAY}$ = sum of short circuit currents of all the strings in the array.

Worked Example 4

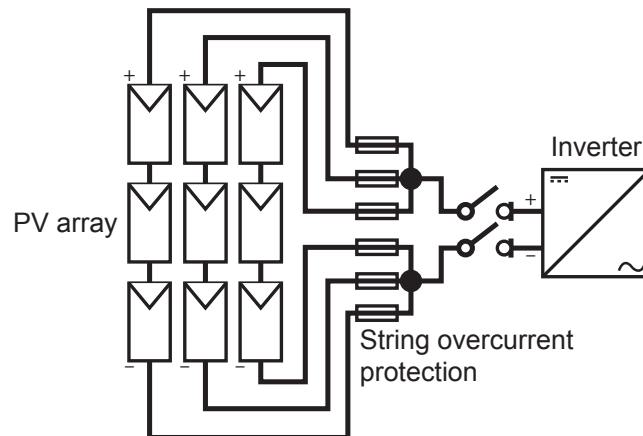

Figure 13: Current carry capacity of cables with string fusing

Note: NEC 2017 only requires protection in one conductor because of the ground protection requirement (Previous versions required in both)

In Figure 13:

- The CCC of the String Cable is rated minimum of the string fuse rating
- The CCC of the Array cable is rated: $1.25 \times 3 \times I_{SC\ MOD}$

Worked Example 5

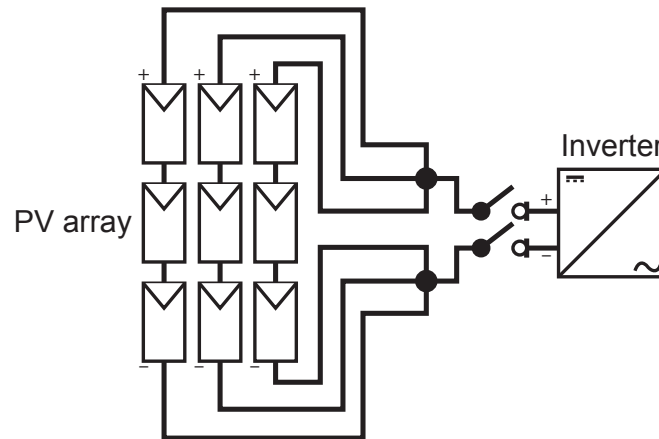

Figure 14: Current carry capacity of cables with no string fusing

In Figure 14:

- The CCC string cable is rated $1.25 \times I_{SC\ MOD} \times (\text{Number of Parallel Connected Strings} - 1) = 1.25 \times I_{SC\ MOD} \times 2$
- The CCC of the Array cable is rated: $1.25 \times 3 \times I_{SC\ MOD}$

6.8 Selection of Cables when Array Comprises Sub-Array PV Systems

- In a large grid connected PV system the array could consist of a number of sub-arrays. A sub-array comprises a number of parallel strings of PV modules. The sub-array is installed in parallel with other sub-arrays to form the full array. The effect of this is to decrease the potential fault current through different parts of the system.

6.8.1 PV Array Cables

- The current carrying capacity (CCC) of the PV array cable will be rated according to:

$$CCC \geq 1.25 \times I_{SC\ ARRAY}$$

Where:

$I_{SC\ ARRAY}$ = sum of short circuit currents of all the strings in the array.

6.8.2 PV Sub-Array Cables

- If a fault current protection device is located in the sub-array cable, the sub-array cable must have a rating equal to or greater than the current rating of the fault current protection device.
- If no fault current protection device has been included, the current carrying capacity of the PV sub-array cable will be rated according to:

$$CCC \geq 1.25 \times I_{SC\ SUB-ARRAY}$$

Where:

$I_{SC\ SUB-ARRAY}$ = sum of short circuit currents of all the other sub-arrays

6.8.3 PV String Cables

- If sub-array fault current protection is used, the current carrying capacity of the string cable will be the rated trip current of the sub-array fault current device plus the fault current of the other strings in the sub-array:

$$CCC \geq I_{TRIP-SUBARRAY} + 1.25 \times I_{SC\ MOD} \times (\text{Number of Strings} - 1)$$

Where:

$I_{SC\ MOD}$ = short circuit current of PV module.

$I_{TRIP-SUBARRAY}$ = the rated trip current of the sub-array fault current protection device.

- If no sub-array fault current protection device is used, the current carrying capacity of the string cable will be according to:

$$CCC \geq 1.25 \times (\text{sum of short circuit currents of all other strings in the array})$$

Worked Example 6

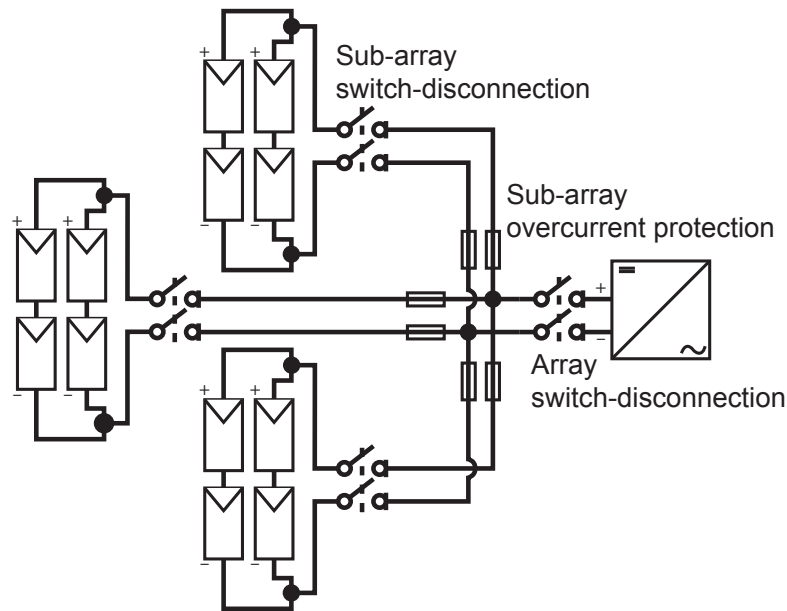

Figure 15: Array with sub-array fusing

Note: NEC 2017 only requires protection in one conductor because of the ground protection requirement (Previous versions required in both)

In Figure 15:

- The CCC of the String Cable is rated

$$I_{trip-subarray} + 1.25 \times I_{SC\ MOD} \times (\text{Number of Strings} - 1) = I_{trip-subarray} + 1.25 \times I_{SC\ MOD} \times 1$$

- The CCC of the subarray shall be a minimum of $I_{trip-subarray}$

- The CCC of the Array cable is rated: $1.25 \times 6 \times I_{SC\ MOD}$

7. Disconnection Requirements within an Array

- Every string shall be capable of being individually disconnected (isolated) from the rest of the system. This disconnection does not have to be a load breaking device. The module connectors can perform this function.
- Sub-arrays shall be capable of being individually disconnected (isolated) from the rest of the system. It is recommended that this is a load-break switch disconnecter.
- The array shall be capable of being isolated by a load breaking switch disconnecter. This is located near the Inverter (Refer to section 16.2).

8. Safe Installation Practice

A dangerous situation occurs when the person installing the system is able to come in contact with the positive and negative outputs of the solar array or sub-array when the output voltage is rated DVC-C (that is greater than 120V dc)

Most grid-connected systems use approved solar modules which are connected using double insulated leads with polarised shrouded plug and socket connections.

Therefore, the dangerous situation is only likely to occur at:

- the PV Array switch-disconnector (isolator) before the inverter;
- AND
- the sub-array and array combiner boxes (if used).

To prevent the possibility of an installer coming in contact with live wires it is recommended practice that one of the interconnect cables of each string (as shown in Figure 16) is left disconnected until all the wiring is complete between the array and the inverter. Only after all switch-disconnectors and other hard-wired connections are completed should the interconnect of the array be connected.

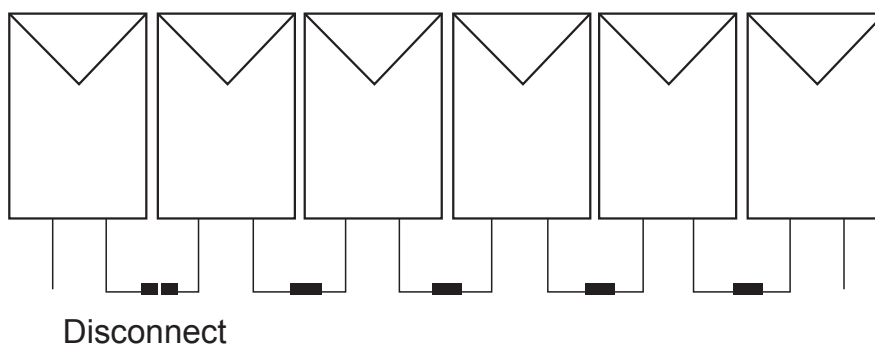

Figure 16: Disconnected interconnect cable

The installer shall ensure that all connectors used are waterproof and connected securely to avoid the possibility of a loose connection. Only connectors of the same type from the same manufacturer are allowed to be mated at a connection point.

When mounted on a roof, the solar module interconnect cables must be supported clear of the roof surface to prevent debris build up or damage to insulation.

9. Earthing (Grounding) of Array Frames for a PV Array with Maximum Voltage Greater than ELV (including AC modules and micro-inverter systems)

- All exposed metal module frames and array mounting frames shall be earthed(grounded) where the PV array has a PV array maximum voltage greater than ELV (DVC-C) or when ac modules or micro inverters with LV outputs are installed.
- A minimum cable size of 4 mm² (NEC states it shall be no smaller than 14 AWG) shall be used but if the array structure is to be earthed (grounded) for lightning protection then it should be minimum 16 mm² (6AWG).
- Earth/ground connection shall be:
 - by a purpose-made fitting providing earthing/grounding or bonding connections for dissimilar metals and fitted to the manufacturer's instructions, or
 - by purpose-made washers with serrations or teeth for the connection between the PV module and mounting frame fitted to the manufacturer's instructions, and
 - arranged so that the removal of a single module earth connection will not affect the continuity of the earthing/grounding or bonding connections to any other module.
- Self-tapping screws shall not be used.
- Ensure that rail joiners (splices) provide earth (ground) continuity. Some rail manufacturers state that the use of a rail joiner (splice) provides earth continuity between rails. If the manufacturer does not provide this information, an earth strap shall be installed across the joint.
- The earth/grounding cable can be insulated unsheathed cable. If exposed to direct sunlight the cable shall have a physical barrier to prevent exposure to direct sunlight.
- The earth/grounding cable should be installed in parallel with and in close proximity to the PV array cable (both positive and negative), the inverter and the inverter ac cables going to the switchboard or distribution board.
- The earthing/grounding conductor from the PV array can connect to inverter's main earth conductor in the ac output cable provided the following conditions are met:
 - Installation is not subject to lightning
 - Inverter ac earth is of an appropriate size
- Earth cable cannot pass through a tile or steel roof without additional mechanical protection (conduit) and an appropriate collar flashing (e.g. Dektite). The same conduit used for PV array cable can also be used for the earth cable.
- All grounding cables should be connected to the same earth grounding point. If multiple grounding points are used, all ground points should be connected together with a grounding cable.

10. Installation of PV Array Cable between Array and Inverter

- PV array cables within buildings installed in: ceiling spaces, wall cavities, under floors, and other hidden locations shall be enclosed in heavy-duty (HD) insulating conduit so that the risk of short-circuit is reduced. In all other locations, it shall be installed in medium-duty conduit as a minimum. (NEC in certain situations requires the cables in metallic raceways or metallic cable trays)
- PV array cables shall be installed in UV-resistant conduits if exposed to the outdoor environment.
- Conduits shall be installed so that they are adequately supported.
- Double insulation of each conductor shall be maintained within wiring enclosures (e.g. conduit).
- The wiring enclosure shall be labelled 'SOLAR' on the exterior surface of the enclosure at an interval not exceeding 2 metres.
- Where the PV array cable and conduit passes through a tile or steel roof, an appropriate collar flashing (e.g. Dektite) shall be installed.
- Installing a conduit just through a hole in a metal roof and sealing it with silicone is prohibited.

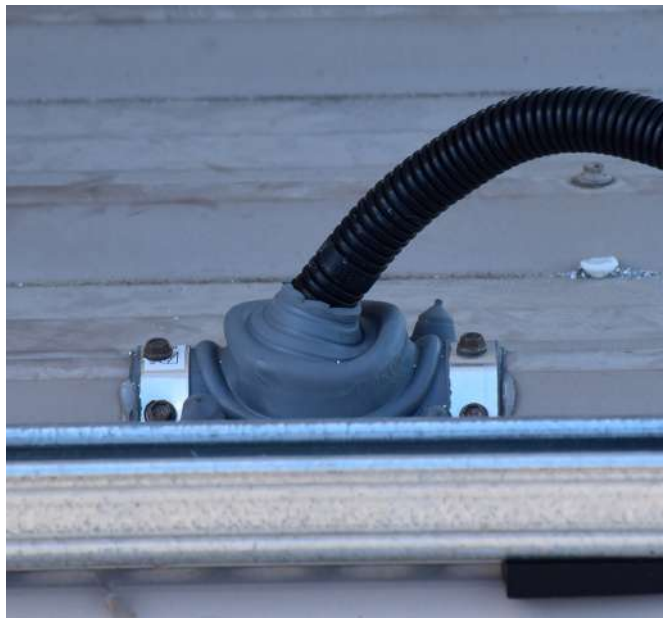

Figure 17: A collar flashing on a metal roof

11. dc Cable Protection

- All cables shall be electrically protected from fault currents that could occur.
- Each solar module has a maximum reverse current rating provided by the manufacturer. If the array consists of parallel strings such that the reverse current flow into a string with a fault is greater than the maximum reverse current for the modules in that string, then protection shall be provided in each string. The protection to be used are dc rated fuses.

Worked Example 7

The reverse current rating for a module is 15A while the short circuit current is 8.9 A. If the array consists of two (2) parallel strings and a fault occurs in one (1) string then the potential fault current will come from the other one (1) string which is only 8.9A and is less than the reverse current rating so no protection is required. However, if the array consists of three (3) parallel strings and a fault occurs in one (1) string then the fault current could come from the other two (2) strings. This current is 17.8 A (2×8.9) and is now greater than the reverse current rating of the module. Protection is now required.

A formula for determining the maximum number of strings allowed before fuses are required is:

$$\begin{aligned} & \text{Maximum Number of Strings without string protection} \\ & = \text{reverse current rating of a module} / I_{sc} \text{ of the module} \end{aligned}$$

So in the above example; Max Number of strings = $15/8.9 = 1.69$ rounded up to 2.

11.1 Fuses

Fuses used in PV arrays shall —

- be rated for dc use;
- have a voltage rating equal to or greater than the PV array maximum voltage determined using the methodology in section 5.2 .
- be rated to interrupt fault currents from the PV array; and
- be of an overcurrent and short circuit current protective type suitable for PV complying with IEC 60269-6 (i.e. Type gPV). or the equivalent through the NEC.

11.2 String Protection

- The fuses shall have the following current rating:

$$1.5 \times I_{SC\ MOD} < I_{TRIP} < 2.4 \times I_{SC\ MOD}$$

and

$$\text{Fuse Rating} < I_{RC\ MOD}$$

Where:

- $I_{SC\ MOD}$ = Module short circuit current
- I_{TRIP} = rated trip current of the fault current protection device.
- $I_{RC\ MOD}$ = Module reverse current rating

Note: For countries following NEC the requirements are:

- Minimum fuse rating: $1.56 \times I_{sc}$ of module (string)
- Maximum fuse rating: less than reverse current rating of the module (string)

11.3 Sub-Array Protection

- An array may be broken up into sub-arrays for different reasons; for example, if two sections of the array are installed in separate areas. The need for sub-array overcurrent protection is similar in logic to that for string overcurrent protection – one sub-array could be operating differently from the other sub-arrays owing to shading or earth faults. The use of sub-array protection is to stop excessive currents from flowing into a sub-array.

11.4 Requirements of Sub-array Overcurrent Protection

- Sub-array overcurrent protection protects a sub-array made up of a group of strings. It is required if one of the following conditions is met:
 - $1.25 \times I_{SC_ARRAY} >$ Current carrying capacity (CCC) of any sub-array cable, switching and connection device.
 - More than two sub-arrays are present within the array.

11.5 Sizing the Sub-array Overcurrent Protection

- If sub-array overcurrent protection is required for a system, the nominal rated current for the overcurrent protection device will be as follows:

$$1.25 \times I_{SC\ SUB-ARRAY} \leq I_{TRIP} \leq 2.4 \times I_{SC\ SUB-ARRAY}$$

Where:

- $I_{SC_SUB-ARRAY}$ = short-circuit current of the sub-array.
 I_{TRIP} = rated trip current of the fault current protection device.

Note: For countries following NEC the requirements are:

- Minimum fuse rating: $1.56 \times I_{sc}$ of sub array

11.6 Array Protection

Array overcurrent protection is designed to protect the entire PV array from external fault currents. In domestic grid-connected systems, array overcurrent protection is generally not required. This is because array protection is only required when an external current source is present in the system to which the PV array is connected.

11.7 Arc Fault Protection (countries following NEC requirements)

NEC Article 690.11 requires PV systems operating at 80 V dc or greater to be protected by a listed PV arc-fault circuit interrupter. The purpose is to detect and interrupt arcing faults.

There are exemptions including:

- PV systems not installed on buildings or in buildings where the building is a detached structure solely for housing PV system equipment.
- PV circuits and dc-to-dc converter output circuits that are direct buried, installed in metallic raceways, or installed in enclosed metallic cable trays.

Refer to the NEC for further information.

11.8 Rapid Shutdown of PV Systems on Buildings (countries following NEC requirements)

NEC Article 690.12 requires PV systems dc wiring installed on or in buildings to include a rapid shutdown device.

There is an exemption for ground mounted arrays frames where:

- the dc array cable never enters a building, or
- when the dc array cable does enter a building, the building is designed specifically to house only PV system equipment.

Refer to the NEC for further information.

12. Installation of Combiner Boxes

- Combiner boxes (PV string or PV array) installed outside shall be at least IP65 and shall be UV resistant.
- PV array and PV string combiner boxes which contain fuses or switch disconnectors shall be located where they can be reached without having to dismantle any structure such as cupboards, structural framing etc.
- Any cable entries into combiner boxes via cable glands or conduit glands should maintain the IP rating of the combiner box.

13. Segregation of dc and ac circuits

- Segregation shall be provided between dc and ac circuits within enclosures by insulation barriers.
- Where switches for dc and ac circuits are mounted on a common mounting rail the mounting rail shall not be conductive (e.g. metal).
- dc and ac circuits should be clearly marked.

14. Plugs and Sockets

Plugs, sockets and connectors shall—

- comply with EN 50521;
- be protected from contact with live parts in connected and disconnected states (e.g. shrouded);
- have a current rating equal to or greater than the current carrying capacity for the circuit to which they are fitted;
- require a deliberate force to separate;
- have a temperature rating suitable for their installation location;
- if multi-polar, be polarized;
- comply with Class II;
- if exposed to the environment, be rated for outdoor use, be of a UV-resistant type and be of an IP rating suitable for the location;

15. Inverter Installation

The inverter shall be installed as to the manufacturer's instructions. The installer shall do the following:

- Ensure the location is appropriate for the IP rating of the inverter. Where this is not possible then the inverter/s should be in an appropriate weatherproof enclosure
- Comply with specific environmental requirements e.g. not in direct sunlight, direct rain, etc
- Ensure mounting structure is able to support inverter weight
- Ensure mounting structure material is appropriate for the inverter
- Recommended clearances shall be followed.

The inverter heat sink shall be clear of any obstacles that may interfere with cooling of the inverter.

- Cables connected to the inverter shall be mechanically secured in such a manner that they cannot be inadvertently unplugged from the inverter. This can be achieved by:
 - Having the inverter housed in an enclosure (with cables suitably supported).
 - The use of an inverter which has the cable connection area of inverter covered by a removable enclosure/cover which protects the supported cables so that there are no exposed, unsupported cable loops.
 - The use of conduit and secure wall fixings

Note: Where the inverter requires dc connectors to be used, a maximum allowable distance of no more than 200 mm (8 inches) of unprotected dc cable shall be permitted between connectors and conduit provided the location is not subject to mechanical damage.

- Where the inverter is exposed to the weather there shall be no open ends of conduit. If a cable is required to exit from a conduit, an appropriate cable gland shall be installed on the end of the conduit to ensure the IP rating is maintained

The installer shall ensure that the grid parameters of the inverter are set to the utility's requirements.

15.1 Inverter Earth (Ground) Fault Indication (for Countries following NEC refer to section 15.3)

- Where the PV array maximum voltage is greater than 120V dc an earth (ground) fault system shall be installed.
- The alarm system may be an audible signal, indicator light or another form of fault communication, e.g. fax, email, SMS. The fault indication shall be installed in a way that it will make the system owner aware of the fault and initiate an action to correct an earth fault.
- Micro inverter and ac module systems typically operate at a PV array maximum voltage less than 120V dc and therefore are not required to have an earth (ground fault) indication, although it is recommended that if the system has that capability it should be installed. (Check the NEC if in a country following that standard)
- Where the system utility uses remote monitoring to inform the customer of an earth fault, the configuration of the remote monitoring shall be provided in the customer's manual

15.2 Additional Requirements for Module Inverters

The following is in addition to the above requirements for all inverters.

- dc cable length is less than 1.5m (5 feet) (including any adaptor cables)
- The method of cable support for the interconnecting ac cable and dc panel cables shall have a life as long as the system.
- Cable support shall ensure that there is no stress placed on connectors.
- Plugs, sockets and connectors shall only be mated with those of the same type from the same manufacturer
- A PV array disconnection device is not required for PV modules connected to micro inverters

15.3 Ground Fault Protection (countries following NEC requirements)

NEC 2017 (690.41) introduced the requirement that PV array shall be with dc ground-fault protection meeting

- The ground fault protective device (GFPD) or system shall detect ground fault(s) in the PV array dc current-carrying conductors and components.
- The circuit with the ground fault shall be interrupted by either:
 - The GFPD disconnecting the conductor with the fault, or
 - The Inverter connected to the conductor with the fault stops providing any output power.

Exception: PV arrays with not more than two PV source circuits and with all PV system dc circuits not on or in buildings shall be permitted without ground-fault protection.

16. Switch Disconnectors

Switch disconnectors are load breaking devices and sometimes called isolators. Within the grid connected PV system switch disconnectors are required as follows:

- PV array dc switch disconnector located near inverter;
- ac switch disconnector located near inverter;
- ac main switch located within the switchboard or distribution board that is interconnected to the inverter.

For micro-inverter installations an ac switch-disconnector is required at the point where the inverter interconnecting cables connect to the cable that is then interconnected to the switch board or distribution board.

Note: Though the disconnection devices are switch-disconnectors the signs shall use the word isolators for simplicity.

16.1 PV Array dc Switch Disconnector near Inverter

- A PV array switch-disconnector(s) shall be installed adjacent to the inverter.
- All PV array switch-disconnectors shall be capable of being reached for inspection, maintenance or repairs without necessitating the dismantling of structural parts, cupboards, benches or the like.
- For inverters with an integrated switch-disconnector: a separate switch-disconnector is not required at the inverter if the switch-disconnector is mechanically interlocked with a replaceable module of the inverter and allows the module to be removed from the section containing the switch-disconnector without risk of electrical hazards.
- Where multiple disconnection devices are required to isolate the array(s) from the inverter(s) they shall be grouped so that they all operate simultaneously, or they shall all be grouped in a common location and have warning signs indicating the need to isolate multiple supplies to isolate the equipment.
 - Where there are multiple isolators, they shall be individually labelled
e.g. "PV Array DC isolator inverter 1 MPPT A"
- Where strings are paralleled at the inverter, it is recommended that this occurs on the inverter side of the disconnection device or in the inverter itself.

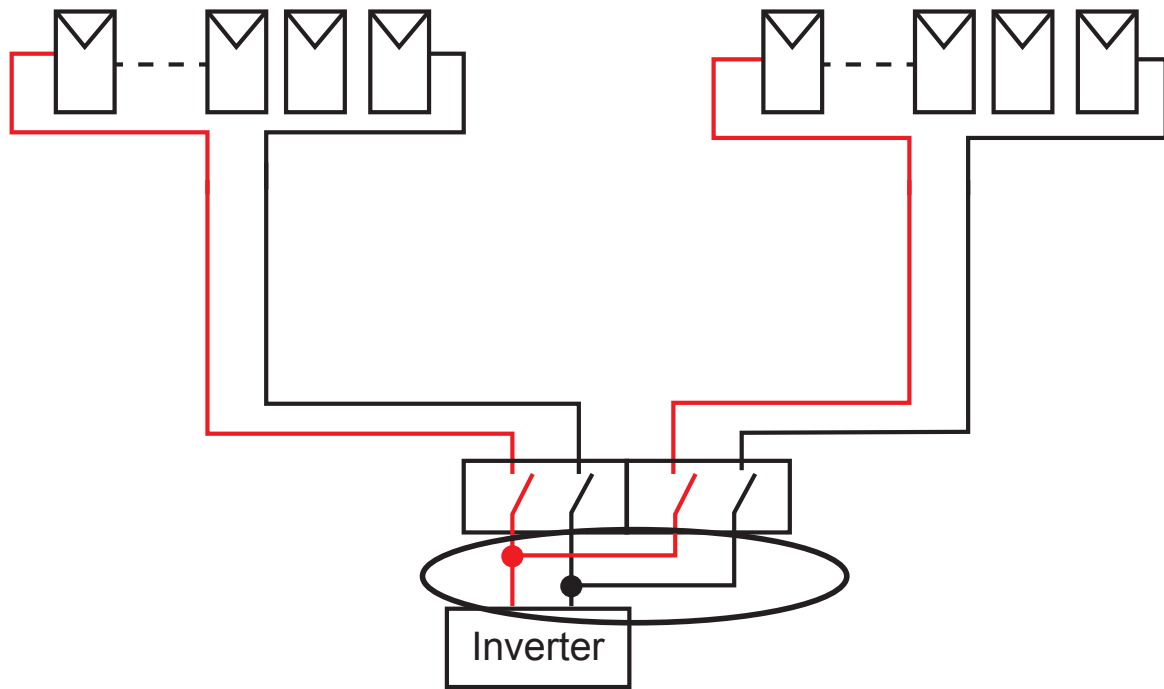

Figure 18: Paralleling of strings on the inverter side of the device

16.2 dc Switch-Disconnecter Requirements

Switch-disconnectors shall:

- be rated for dc use.
- be rated to interrupt full load and prospective fault currents
- not be polarity sensitive.
- interrupt all live conductors simultaneously.
- not have exposed live parts in either the connected or disconnected state.
- comply either with the requirements of IEC 60947-3 and shall have a utilization category of at least DC-21B (as per IEC 60947-3) or comply with the requirements of NEC.
- Have voltage ratings as follows:
 - For non-functionally earthed systems, isolated inverters (transformer based): the voltage rating of both poles together of the switch-disconnector shall be at least the PV array maximum voltage (V_{oc} of the array adjusted for the lowest ambient temperature at site)
 - For non-isolated inverters (transformerless based): the voltage rating of each pole of the disconnector shall be at least the PV array maximum voltage (V_{oc} of the array adjusted for the lowest ambient temperature at the site)

Note: Full load current for the PV array disconnector is $1.25 \times$ the array short circuit current. For those countries using the NEC standard there is an oversize factor of 125% resulting the main PV array switch disconnector being required to be rate at 1.56 time the array short circuit current.

16.3 ac Switch-Disconnecter near Inverter

- Where the inverter is not within 3 meters (10 feet) and in the line of sight of the switchboard to which it is connected, an isolator shall be provided at the inverter so that a person operating the switch has a clear view of any person working on the inverter. (refer to Figure 19 , Figure 20 and Figure 21).

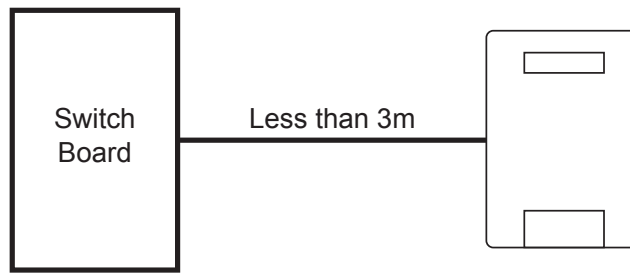

Figure 19: An ac switch-disconnector is not required - the distance between the switchboard and the inverter is less than 3m (10 feet) and the inverter is visible from the switchboard

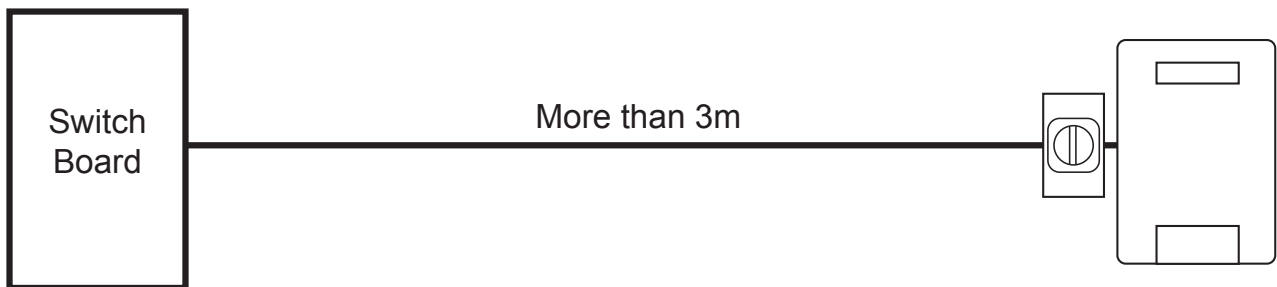

Figure 20: An ac switch-disconnector is required- the distance is greater than 3m or the switchboard is not visible from the inverter

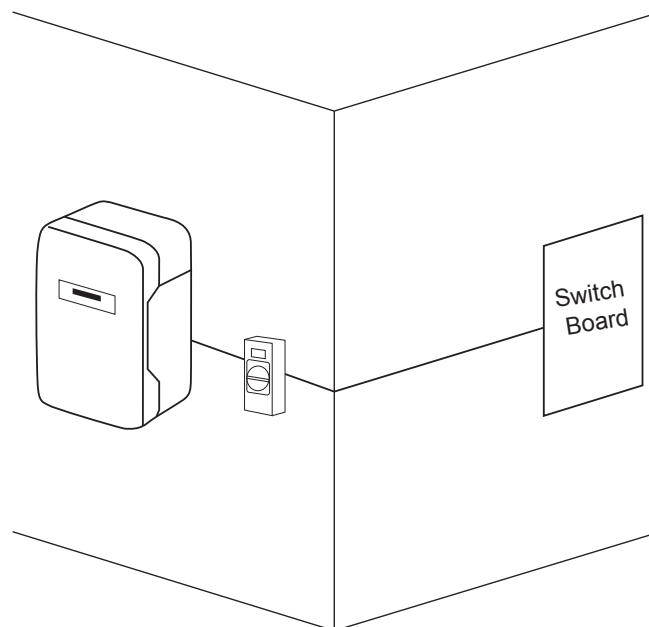

Figure 21: An ac switch-disconnector required - the switchboard is away from the line of sight

- Where the disconnection device is exposed to the weather, it shall have an IP rating of at least IP56, however it is recommended that they are rated to IP66.
- It is recommended that there are no top entries into the switch-disconnector and drip loops are utilised at the bottom of the switch-disconnector to minimise risk of water ingress.
- The switch shall have a minimum current rating equal to the maximum ac rating of the inverter.

16.4 Solar Supply Main Switch in Switchboard

- The inverter should be connected directly to the main switchboard via a main switch.
- Where this is not possible or not desirable, the inverter energy system should be connected to the distribution board located physically nearest to the inverter, and the main switchboard.
- The main switch for the switchboard or the distribution board, to which the inverter is connected, shall be a lockable circuit breaker to provide protection for the cable to the inverter.

16.5 ac Isolator for Micro Inverter Installation

- A labelled, lockable, switch-disconnector (inverter ac isolator) shall be installed at the point of transition from the micro inverter interconnect cable to fixed wiring. The purpose of the ac isolator is to de-energise the ac from the micro inverter(s) for maintenance or fault rectification
- The isolator shall be installed adjacent to the inverter or inverter group. This switch-disconnector may be a single switch-disconnector and can be used to isolate multiple adjacent inverters.
- Where micro inverters are not installed adjacent to each other, additional switch-disconnectors shall be installed.
- Switch-disconnector enclosures shall be IP56 rated, however it is recommended that it is rated to IP66
- All entry points (conduit and cable glands) to the switch-disconnector enclosure should be on the lower end of the enclosure either underneath or facing down the roof.
- If exposed to the weather a secondary shield is recommended to shelter the inverter ac switch-disconnector from direct exposure to rain and sun.

17. Installation of ac Cable between Inverter and the Grid

- The installation of the ac cabling shall comply with any local wiring requirements.
- The inverter shall be connected by fixed wiring to a dedicated circuit on a switchboard or distribution board.
- All ac cables between the inverter and any switchboard and all the cables between any distribution boards and a main switchboard which carry current from the inverter shall be rated for at least the full output current of the inverter energy system.
- It is recommended that the voltage drop (based on the maximum ac current from the inverter(s) between the inverter ac terminals and the point of connection to the grid (supply) should be kept as small as possible (recommended <1%) to minimise voltage rise within the installation. This will limit inverter disconnections in areas where the grid voltage may be high to decrease incidents of overvoltage trips for inverters. This is also an issue for micro inverter installations where the ac cable run may be long.

17.1 Voltage Drop in ac Cables

For ac cables the formulas in section 6 are applied with addition of power factor ($\cos \Phi$). The resultant formula for determining the voltage drop on single phase ac cables is as follows:

The metric formula is:

$$V_d = \frac{2 \times L_{CABLE} \times I \times \cos \Phi \times \rho}{A_{CABLE}}$$

Where:

- L_{CABLE} = route length of cable in metres (multiplying it by two adjusts for total circuit wire length since a complete circuit requires a wire out and another wire back along the route).
 I = current in amperes.
 ρ = resistivity of the wire in $\Omega/\text{m}/\text{mm}^2$
 A_{CABLE} = cross sectional area (CSA) of cable in mm^2 .
 $\cos \Phi$ = power factor

The imperial formula is;

$$V_d = \frac{I \times \cos \Phi \times 2 \times d}{1000 \text{ ft /kft}} \times \left(\frac{\Omega}{\text{kft}} \right)$$

Where:

- V_d = voltage drop
 d = route length of dc cable in feet (2 x adjusts for total circuit wire length)
 I = dc current in amperes (commonly I_{mp})
 Ω/kft = ohms/thousand feet (resistance)
 $\cos \Phi$ = power factor

18. Shutdown Procedure

- A shutdown procedure is required to ensure safe de-energisation of the system.
 - The shutdown procedure shall reflect the specific requirements of the individual system.
 - All isolating switches (switch-disconnectors) referred to in the shutdown procedure shall correspond to individual switch-disconnector (isolator) labels (e.g “PV array dc isolator”, “Solar Supply Main Switch”).
 - For central inverter systems, an engraved label showing the shutdown procedure shall be installed adjacent to the inverter. An example shutdown procedure would be:
 - 1. Turn off the main switch solar supply at the ac switchboard and then the ac isolator at the inverter (where installed) then
 - 2. Turn off the PV array dc isolator at the inverter.
- WARNING:** PV array dc isolators do not de-energise the PV array and array cabling using the module interconnectors.
- Micro inverter systems and AC module system switching shall be installed at the switchboard to which the inverter is connected. An example shutdown procedure would be:
 - Turn off the main switch solar supply at the AC switchboard. This will isolate the PV array.
 - DC Conditioning Units. The shut-down procedure must reflect the specific requirements of the individual system.

19. Metering

- The installer shall notify the customer of the metering processes.
- If the metering arrangement with the local electrical utility does not allow metering of the ac output energy of the grid connected PV systems, it is recommended that if the inverter does not have that capability then a separate meter is installed. This will help to verify that the system is performing as expected.

20. Signage

- A sign should be included in the switchboard stating:
'WARNING', 'MULTIPLE SUPPLIES' and 'ISOLATE ALL SUPPLIES BEFORE WORKING ON THIS SWITCHBOARD'
 - A sign with text 'MAIN SWITCH (SOLAR SUPPLY)' shall be permanently fixed adjacent to the main switch for the inverter
 - Where the inverter is connected to the main switchboard, a sign with text 'MAIN SWITCH GRID SUPPLY)' shall be permanently fixed adjacent to the main switch for the grid supply
 - Where the inverter is connected to the distribution switchboard, a sign with text 'MAIN ISOLATOR (NORMAL SUPPLY)' shall be permanently fixed adjacent to the isolator for the normal supply to the distribution switchboard
- Note:** The terms 'grid supply', 'normal supply' and 'mains supply' can be used alternatively
- If the inverter is not mounted near the switchboard then there should be a sign in the switchboard stating where the inverter is located.
 - There should be a sign on the switchboard stating the location of the PV array, the maximum dc array short circuit current and array open circuit voltage from the system.
 - Any junction boxes used between the array and the inverter should have a sign 'WARNING: HAZARDOUS dc VOLTAGE' on the cover.
 - A sign with text 'PV ARRAY dc ISOLATOR' shall be fixed permanently adjacent to the PV array dc disconnect
 - Where there are multiple disconnection devices, a sign with texts 'WARNING: MULTIPLE dc SOURCES' and 'TURN OFF ALL dc ISOLATORS TO ISOLATE EQUIPMENT' shall be fixed near the inverter
 - A sign with steps to safely shut down the system shall be fixed adjacent to and visible from the equipment to be operated in the event of shutdown. This sign may also include detailed steps of the start-up procedure.

21. Commissioning

The commissioning sheets provided with these guidelines (Appendix 2) should be completed by the installer. A completed copy shall be provided to the customer in the system documentation and a copy retained by the installer.

21.1 Short Circuit Current Measurement

Where short circuit currents are required, undertake the following steps to measure the short circuit current safely as shown in Figure 22.

- Ensure each string fuse (where required) is not connected or that LV array is disconnected somewhere in each string as shown in Figure 16 of these guidelines.
- Leave solar array cable connected to the PV array switch disconnecter.
- Remove the cable from the PV array switch disconnecter to the inverter.
- With the PV array switch disconnecter off - put a link or small cable between the positive and negative outputs of the PV array switch disconnecter.
- Install the string fuse for string 1 or connect the string disconnect (figure 16) to complete the wiring of the string. Turn on PV array switch disconnecter - using a dc clamp meter, measure the dc short circuit current for String 1. Turn off the PV array switch disconnecter. Disconnect string fuse for string 1 or remove the disconnecter to break the string circuit.
- Repeat for each string

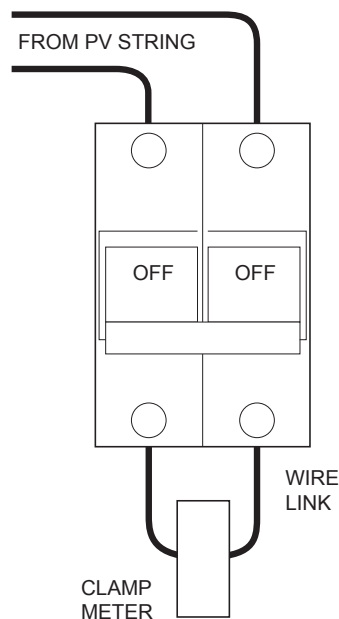

Figure 22: Measuring short circuit current

21.2 Insulation Resistance Measurement

Warning: PV array dc circuits are always live during daylight and unlike conventional ac circuits cannot be isolated before performing this test.

The insulation resistance test should be undertaken when all the system wiring has been completed.

The insulation resistance test shall be carried out with an insulation test device connected between earth and the PV array positive connection, and then the test repeated with the test device connected between earth and PV array negative connection. Test leads should be made secure before carrying out the test. The values of insulation resistance shall be recorded. Table 5 shows the minimum values that should be achieved for different system voltages.

Table 5: Minimum insulation resistance for various system voltages

SYSTEM VOLTAGE (V × 1.25)	TEST VOLTAGE	MINIMUM INSULATION RESISTANCE, MΩ
< 120	250	0.5
120 – 500	500	1
> 500	1000	1

22. Documentation

All complex systems require a user manual for the customer. Grid-connected PV systems are no different. The documentation for system installation that shall be provided shall include:

- List of equipment supplied with model, description and serial numbers
- List of action to be taken in the event of an earth fault alarm
- Shutdown and isolation procedure for emergencies and maintenance
- Maintenance procedures and timetable
- Commissioning sheet and installation checklist
- Warranty information
- A basic connection diagram that includes electrical ratings of the PV array and the ratings of all overcurrent devices and switches as installed
- System performance estimate
- Equipment manufacturer's documentation and handbooks for all equipment supplied
- Array frame engineering certificate for wind and mechanical loading
- Installer/designer's declaration of compliance
- Voltage rise calculations or measurements
- Details of central protection, phase balancing or export controls installed

Appendix 1: Temperature Conversion Tables

°F	°C	°F	°C	°F	°C
32	0	64	18	96	36
33	1	65	18	97	36
34	1	66	19	98	37
35	2	67	19	99	37
36	2	68	20	100	38
37	3	69	21	101	38
38	3	70	21	102	39
39	4	71	22	103	39
40	4	72	22	104	40
41	5	73	23	105	41
42	5	74	23	106	41
43	6	75	24	107	42
44	6	76	24	108	42
45	7	77	25	109	43
46	8	78	26	110	43
47	8	79	26	111	44
48	9	80	27	112	44
49	9	81	27	113	45
50	10	82	28	114	46
51	11	83	28	115	46
52	11	84	29	116	47
53	12	85	29	117	47
54	12	86	30	118	48
55	13	87	31	119	48
56	13	88	31	120	49
57	14	89	32	121	49
58	14	90	32	122	50
59	15	91	33	123	51
60	16	92	33	124	51
61	16	93	34	125	52
62	17	94	34	126	52
63	17	95	35	127	53

Appendix 2: Installation and Commissioning Sample

Installer name:

Installer signature:

Commissioning date:

Installation address:

Client name:

Client contact details:

PV module manufacturer:

PV module model number:

Inverter No1 Manufacturer

Inverter No 1 Model Number

Inverter No2 Manufacturer

Inverter No 2 Model Number

Inverter No3 Manufacturer

Inverter No 3 Model Number

All PV modules connected to the same MPPT are of the same make and model or have similar rated electrical characteristics:

YES NO

All PV modules connected to the same string have the same angle of tilt and azimuth:

YES NO

Number of modules in series:

Number of strings in parallel:

String 1:

Sub-array 1:

String 2:

Sub-array 2:

String 3:

Sub-array 3:

String n: (add more as required)

Sub-array n: (add more as required)

Array mounting system manufacturer:

Array mounting system model:

Array mounting system certified for installation site parameters with respect to wind speeds

YES NO

Array mounting system does not use or contact any galvanically dissimilar metals:

YES NO

All penetrations and fixings are suitably sealed and weatherproofed:

YES NO

PV array voltage complies with site regulations:	YES <input type="checkbox"/>	NO <input type="checkbox"/>	
PV system wiring is suitably protected from mechanical action:	YES <input type="checkbox"/>	NO <input type="checkbox"/>	
PV array uses single-core double-insulated cabling compliant to relevant standards:	YES <input type="checkbox"/>	NO <input type="checkbox"/>	
Overcurrent protection is provided where required:	YES <input type="checkbox"/>	NO <input type="checkbox"/>	NOT REQUIRED <input type="checkbox"/>
PV array uses single-core double-insulated cabling compliant to relevant standards:	YES <input type="checkbox"/>	NO <input type="checkbox"/>	
All dc components (switch disconnectors, cables, fuses etc) and cables are rated correctly for dc usage and have voltage ratings greater than or equal to the PV array maximum voltage:	YES <input type="checkbox"/>	NO <input type="checkbox"/>	
All ac components are rated correctly for AC usage	YES <input type="checkbox"/>	NO <input type="checkbox"/>	
All components are suitable for their environment and have the appropriate IP and UV ratings:	YES <input type="checkbox"/>	NO <input type="checkbox"/>	
Disconnection devices and protection devices (where installed) are readily accessible in the case of maintenance or emergency:	YES <input type="checkbox"/>	NO <input type="checkbox"/>	
Disconnecting devices comply with frequency-of-use requirements and are rated for the temperature-adjusted operational circuit current:	YES <input type="checkbox"/>	NO <input type="checkbox"/>	
PV Array switch-disconnectors are rated to switch full-load currents and are not polarity-sensitive:	YES <input type="checkbox"/>	NO <input type="checkbox"/>	
PV array switch-disconnectors interrupt all live conductors:	YES <input type="checkbox"/>	NO <input type="checkbox"/>	
PV conductor current-carrying capacity is equal to or greater than the potential system fault current or the overcurrent protection (where installed):	YES <input type="checkbox"/>	NO <input type="checkbox"/>	
PV cabling, where exposed to the elements, is UV-resistant or installed in UV-resistant enclosures:	YES <input type="checkbox"/>	NO <input type="checkbox"/>	
A method of securing cabling has been used that will last the lifetime of the system:	YES <input type="checkbox"/>	NO <input type="checkbox"/>	
DC cabling within buildings is enclosed in heavy-duty-rated protection:	YES <input type="checkbox"/>	NO <input type="checkbox"/>	NOT REQUIRED <input type="checkbox"/>
Combiner boxes are installed according to manufacturer recommendations:	YES <input type="checkbox"/>	NO <input type="checkbox"/>	

Combiner boxes are suitably protected from the environment using appropriate bottom-entry cable glands: YES NO

Double insulation between all conductors is maintained throughout the system: YES NO

PV plugs, sockets and connectors comply with relevant standards, are rated for the installation environment and connected only with the same make and model: YES NO

Blocking and bypass diodes, where installed external to the PV module are suitably protected and graded according to relevant standards and system parameters: YES NO

Overcurrent protection (where required) is installed at the end of the conductor that is most electrically remote from the PV modules: YES NO NOT REQUIRED

A dc switch-disconnector is located adjacent to the inverter if the array is not in the line of sight with the inverter: YES NO

Where multiple dc disconnection devices are installed, they are ganged together or grouped and labelled such that it is clear that all must be operated to isolate the system: YES NO NOT REQUIRED

All exposed metal module frames and mounting equipment are earthed and equipotentially bonded in accordance with the relevant standards: YES NO

Equipment used for PV module and mounting frame earth connections is fit for that purpose: YES NO

Earthing/grounding has been arranged so that the removal of a single module earth connection will not disrupt the continuity of the bonding connections for the rest of the array: YES NO

Earthing/grounding conductor type and size comply with the relevant standards: YES NO

PV array functional earthing is done close to or within the inverter and is done according to the relevant standards: YES NO NOT REQUIRED

The inverter complies with the relevant country standards: YES NO

The inverter installation complies with the manufacturer's instructions, the distribution network service provider's rules and regulations and relevant legislation:

YES NO

Inverters connected to LV PV arrays have an internal or external earth fault alarm system:

YES NO

Signage and labelling conforms to the relevant standards and guidelines:

YES NO

Example test records

The following pages contain example test records that may be used as part of the system commissioning.
PV Array dc

Note: +ve = positive

-ve = negative

If array is LV (120–1,500 V), there is no voltage on input side of array (or string) combiner box (if one is installed)

There is no voltage on output side of array combiner box (if one is installed)

Continuity between strings and array combiner box:

String 1 +ve

String 1 -ve

String 2 +ve

String 2 -ve

String 3 +ve

String 3 -ve

String 4 +ve

String 4 -ve

Correct polarity between strings and array combiner box:

String 1

String 2

String 3

String 4

Open circuit voltages:	
String 1V
String 2V
String 3V
String 4V
Continuity between array combiner box and PV array DC switch-disconnector:	
Sub-array +ve	<input type="checkbox"/>
Sub-array -ve	<input type="checkbox"/>
Correct polarity between array junction box and PV array DC switch-disconnector	<input type="checkbox"/>
Sub-array V_{oc}V
Short circuit currents:	
String 1A
String 2A
String 3A
String 4A
Short circuit current arrayA
Reconnect the strings one at a time by reconnecting the string overcurrent protection (fuses) or reconnecting any module connectors.	
Open circuit voltage at input side of PV array dc switch-disconnectorV
Continuity between PV array dc switch-disconnector and inverter:	
Array +ve	<input type="checkbox"/>
Array -ve	<input type="checkbox"/>
Correct polarity between PV array dc switch-disconnector and inverter	<input type="checkbox"/>

Inverter ac

Note: Following has been written for single phase based on 230V in south pacific.

It will need to be altered to suit the North Pacific where there can be two 120V sides with neutral in middle.

Continuity between inverter and kWh meter:	
Active (Line)V
NeutralV
Continuity between kWh meter and PV inverter AC disconnecter:	
Active (Line)	<input type="checkbox"/>
Neutral	<input type="checkbox"/>
Correct polarity between kWh meter and PV inverter AC disconnecter	<input type="checkbox"/>
Correct polarity at output of PV inverter AC switch-disconnecter from grid	<input type="checkbox"/>
Voltage at output of PV inverter AC switch-disconnecter from gridV
Initial reading of kWh meter

Insulation Resistance

Continuity between inverter and kWh meter:	
Array Positive to Earth (ground)	MΩ
Array negative to Earth (ground)	MΩ

Start-up of system

Refer to system manual for the inverter and follow start-up procedure. This generally involves turning on the PV array dc switch-disconnector followed by the inverter ac switch-disconnector, but the procedures as recommended by the inverter manufacturer must be followed.

System connects to grid

When inverter ac switch-disconnector and PV array ac switch-disconnector are turned on and inverter start-up procedure followed:

Voltage at dc input of inverterV

Voltage within operating limits of inverter

Voltage at ac output of inverterV

Current at ac output to inverterA

@ Irradiance value ofW/m²

Input power of the inverter (if available)W

Output power of the inverter (if available)W

Output power is as expected

System disconnects from grid when inverter ac switch-disconnector is turned off